

TEWC 154 - TRADESPERSONS ELECTRICAL WORK CERTIFICATE MARKING SCHEDULE

- Notes: 1. (1 mark) means that the preceding statement/answer earns 1 mark.
2. This schedule sets out the expected answers to the examination questions. The marker can exercise their discretion and decide on the overall accuracy of any answer that is presented in the candidate's own words.
3. Symbols and terms - alternatives
Power W or P
Voltage V or E or U
Phase Active

Section 1 – All Candidates

Question 1	<i>Marks</i>	<i>Reference</i>	<i>Marking notes</i>
(a) (i) The 20Ω element	(1 mark)		
(ii) The 30Ω element	(1 mark)		

Question 1*Marks**Reference**Marking notes*

(b) Any TWO of:

(2 marks)

- It prevents the element from bulging out the side of the carrier and being accessible to touch.
- Under overload conditions the heat produced in the element is confined to the tunnel area.
- Under short-circuit conditions the arc and molten element is confined within the fuse carrier and base.
- Allows the fuse carrier to sit properly in the fuse holder

(c) (i) In relation to fittings or electrical appliances, means that the fittings or appliances are deliberately disconnected from any source of electricity

(1 mark)

ER 2

(ii) Means charged with electricity so that a difference in voltage exists to earth or between conductors

(1 mark)

ER 2

(d) It will provide protection for the extension leads between the transformer and the appliance.

(2 marks)

Question 1*Marks**Reference**Marking notes*

(e) Divide the power rating by the voltage.

(2 marks)

$$I = \frac{W}{V}$$

(f) • A fault in the fixed wiring circuit.

(1 mark)

- A registered electrician must be called to repair the fault.

(1 mark)

(g) Any TWO of:

(2 marks)

- The appliance is fixed wired and connected through a continuous flexible cord to a supply of electricity from a source isolated from earth with a voltage between conductors not exceeding 250 volts:
- The appliance is supplied with electricity from a safety extra-low voltage source.
- The appliance is double insulated and is supplied with electricity through a RCD

ER 77(3)(a)

ER 77(3)(b)

ER 77(3)(c)

Question 1*Marks**Reference**Marking notes*

- The appliance is supplied with electricity from a monitored earth circuit where the supply to the appliance is automatically disconnected in the event of the earth to the appliance being broken or disconnected: ER 77(4)(b)
- The appliance is supplied with electricity from a source connected to earth in such a way that the voltage to earth will not exceed 55 volts a.c: ER 77(4)(c)
- The appliance is supplied with electricity through a RCD ER 77(4)(d)
- The appliance is supplied with electricity from a source isolated from earth with a voltage between conductors not exceeding 250 volts ER 77(4)(e)
- The appliance is double insulated: ER 77(4)(f)

Question 1*Marks**Reference**Marking notes*(h) Any **TWO** of:

(2 marks)

- High electrical resistance or dielectric strength.
- Good flexibility.
- Non absorbent.
- Withstand mechanical stress.
- Withstand corrosive environments
- Withstand the ambient temperature.
- Withstand heat from the circuit conductors.
- Abrasion resistance.

(i) Any TWO of:

(2 marks)

- Insulation resistance test.
- Polarity test.
- Protective earthing conductor resistance test.
- Circuit continuity test.

(j) Any TWO of:

(2 marks)

- Voltage applied.
- Current level .
- Contact duration.
- Skin dryness.
- Current path.

Question 2*Marks**Reference**Marking notes*

- (a) Any TWO of: (2 marks)
- Disconnect the load.
 - Hold face well back and averted when withdrawing/replacing the carrier.
 - Wear personal protective equipment
 - Withdraw, and replace, carrier with firm, fast action.
- (b) • The test instrument functions correctly. (1 mark)
- That the circuit to be worked on has been correctly isolated and is safe to work on. (1 mark)
- (c) • Check the test instrument on a known live source. This proves that the meter is working correctly. (1 mark)
- Test for isolation (between all conductors) on the circuit being isolated. (1 mark)
- Re-check the test instrument on the known live source. This ensures that it is working correctly. (1 mark)
- (d) (i) To ensure an isolated circuit remains isolated until the person who attached the tag changes the status of the circuit. (1 mark)

Question 2*Marks**Reference**Marking notes*

- (ii) • The word "danger" or "do not operate" on both sides. (2 marks)
- The name of the person whose tag it is
 - Identification and location of the equipment being worked on
 - The date the tag was placed.

Question 3

Marks

Reference

Marking notes

(a) Any **FOUR** of – from AS/NZS 3760:2001:

(4 marks)

- Check for obvious damage or defects in the accessories or plugs.
- Check that flexible cords are effectively anchored to equipment and plugs.
- Check that the inner cores of flexible supply cords are not exposed or twisted;
- Check that the external sheaths are not cut, abraded, twisted, or damaged to such an extent that the insulation of the inner cores is visible
- Check that unprotected conductors or insulation tape are not in evidence.
- Check that any controls are in good working order i.e. they are secure, aligned and appropriately identified.
- Check that covers, guards and the like are secured in the manner intended by the manufacturer or supplier.
- Check that safety facilities and devices are in good working order.
- Check that ventilation inlets and exhausts are unobstructed.

Or

Question 3

Marks

Reference

Marking notes

Any **FOUR** of – from AS/NZS 3760:2003:

- Check for obvious damage or defects in the accessories or plugs.
- Check for discolouration that may indicate exposure to heat, chemicals and moisture.
- Check that flexible cords are effectively anchored to equipment and plugs.
- Check that the inner cores of flexible supply cords are not exposed or twisted;
- Check that the external sheaths are not cut, abraded, twisted, or damaged to such an extent that the insulation of the inner cores is visible
- Check that unprotected conductors or banding insulation tape are not in evidence.
- Check that any operating controls are in good working order i.e. they are secure, aligned and appropriately identified.
- Check that covers, guards and the like are secured in the manner intended by the manufacturer or supplier.
- Check that ventilation inlets and exhausts are unobstructed.
- The pins of insulated pin plugs should be inspected for damage to the insulation of the pins.

Question 3*Marks**Reference**Marking notes***(b) Test No.1**

- | | | |
|--|----------|---|
| (1) Protective earthing conductor (earth continuity) test | (1 mark) | AS/NZS 3760
2001: 2.3.3.1
2003: 2.3.3.1 |
| (2) Any ONE of: <ul style="list-style-type: none">• Any meter that can accurately read values of less than 1Ω.• An ohmmeter that is of Class 5 accuracy or better | (1 mark) | |
| (3) Maximum 1 ohm | (1 mark) | AS/NZS 3760
2001: 2.3.3.1
2003: 2.3.3.1 |

Test No.2

- | | | |
|--|----------|--|
| (1) Insulation resistance test. | (1 mark) | AS/NZS 3760:
2001: 2.3.3.2
2003: 2.3.3.2 |
| (2) Insulation resistance tester | (1 mark) | AS/NZS 3760
2001: 2.3.3.2
2003: 2.3.3.2(b) |
| (3) Any ONE of: <ul style="list-style-type: none">• Not less than 1 MΩ• Not less than 10,000Ω | (1 mark) | AS/NZS 3760
2001: 2.3.3.2(a)
2003: Table 2 |

Question 4

Marks

Marking notes

(a)

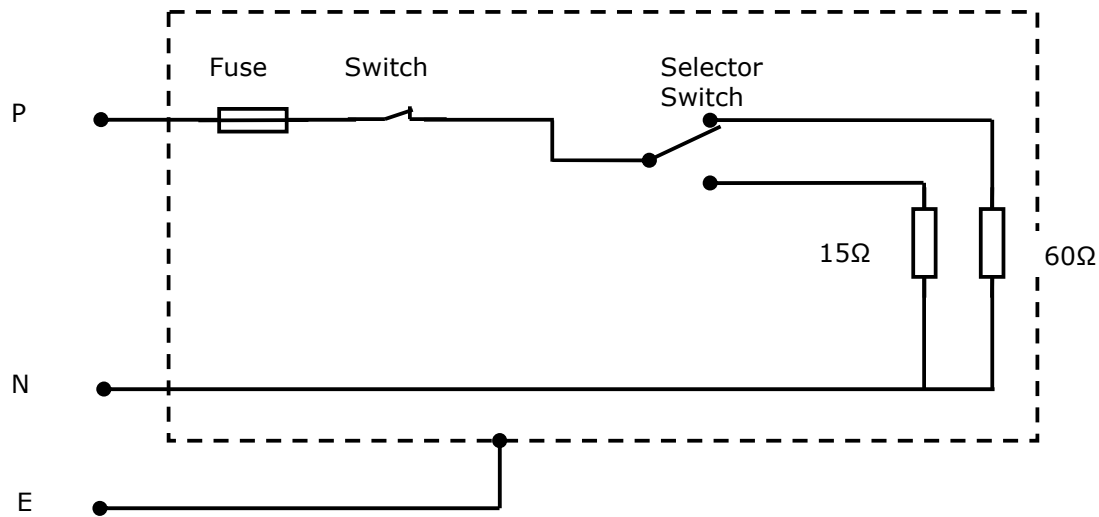

- Correct polarity (1½ marks) Hazardous
- The fuse is in the phase and protects the whole circuit (½ mark) Failure to correctly earth the appliance
- The switch is in the phase and controls the whole circuit. (½ mark)
- The selector switch is connected so two different load settings can be achieved. (1 mark)
- The elements are connected in parallel. (½ mark)
- Working circuit. (1 mark)

Question 4

	<i>Marks</i>	<i>Marking notes</i>
(b) $I = \frac{V}{R}$	(1/2 mark)	
$= \frac{230}{15}$	(1/2 mark)	
$= 15.33 \text{ A}$	(1 mark)	
(c) $P = V \times I$	(1/2 mark)	
$= 230 \times 15.33$	(1/2 mark)	
$= 3525.9 \text{ W}$	(1 mark)	
(d) A 20A is the most suitable fuse	(1 mark)	

Section 2 - Plumbers Only

Question 5

Marks

Reference

Marking notes

- | | | | |
|-----|--|-----------|--|
| (a) | • Use an ohmmeter
Or
A meter that can accurately read values of less than 1 ohm. | (1 mark) | |
| | • Test between the earth pin of the plug and the frame of the appliance. | (2 marks) | |
| | • Maximum acceptable value 1 ohm. | (2 marks) | |
| (b) | • Use an insulation tester. | (1 mark) | |
| | • 500V d.c. test voltage. | (1 mark) | |
| | • Minimum acceptable value 1 MΩ. | (1 mark) | |
| | • Test between the bridged phase & neutral and the frame of the appliance | (2 marks) | |

Question 6*Marks**Reference**Marking notes*

- (a) (i) • The motor will operate normally (1 mark)
- The motor circuitry could be live whilst switched off (1 mark)
- (ii) Any ONE of: (1 mark)
- The motor will operate normally
 - The protective earthing conductor is the wrong colour – potential hazard.
- (iii) • The motor will not operate (1 mark)
- Its framework will be alive at 230V to earth (2 marks)
An immediate and serious shock hazard exists.
OR
Could operate the protective device
- (iv) Any ONE of: (1 mark)
- Earth continuity test
 - Polarity test

Question 6*Marks**Reference**Marking notes*

(b) Any THREE of:

(3 marks)

- The wrong isolating switch has been operated.
- The wrong fuses or circuit breakers have been operated.
- The isolating switch is faulty.
- The circuit is being fed from two different sources.
- The isolating switch is not in the Active conductor.

Question 7*Marks**Reference**Marking notes*

- (a) (i) The method has to show:
- Identification of the fuse on the switchboard for the water heater. (1 mark)
 - Removing the load from circuit and then remove the fuse carrier (1 mark)
 - Testing for isolation at the supply side of the permanent connect unit using the prove-test-prove method. (2 marks)
- (ii) The method has to show:
- Identification of the correct fuse on the switchboard by a process of elimination. (1 mark)
 - Re-testing for isolation at the supply side of the permanent connect unit using the prove-test-prove method. (2 marks)
 - Attaching a danger tag to the fuses. (1 mark)
- (b) • Ensure the permanent connection unit cover is securely fixed in place to prevent access to live parts. (2 marks)

Question 8*Marks**Reference**Marking notes*

- (a) The neutral and phase currents are balanced. (1 mark)
- (b) • Neutral current out of balance with the phase current. (1 mark)
- A magnetic field is induced into the iron core. (1 mark)
- The induced magnetic field induces a current in the sensing coil (1 mark)
- The tripping coil is energised, opening the RCD contacts (1 mark)
- (c) RCD (1 mark)
- To ensure the tripping mechanism has not become stuck or "frozen"
- or
- To ensure it works correctly (rapidly)
- or
- PRCD
- To ensure the tripping mechanism has not become stuck or "frozen"
- or
- To ensure PRCD does not reset to the "on" position after supply is re-established.

Question 8*Marks**Reference**Marking notes*

- (d) (i) 300ms or 0.3 seconds (1 mark)
- (ii) 40ms or 0.04 seconds (1 mark)
- (e) PRCDs are voltage dependent to ensure that, when supply is lost:
- Portable or hand-held appliances do not automatically restart when supply is restored. (1 mark)
 - The PRCD has to be manually reset to restore the supply. (1 mark)

(

Question 9*Marks**Reference**Marking notes*

(a) (i) Any ONE of:

(2 marks)

- A coding system to indicate the degree of protection provided by the enclosure against access to live parts from solid objects, or the ingress of water or other liquids
- Degrees of enclosure protection for electrical equipment
- A degree of protection in accordance with AS 1939.
- A degree of protection in accordance with AS 60529.
- A degree of protection of an item of enclosed equipment is expressed as an IP (International Protection) rating in accordance with AS 60529.

AS 1939
supplement 1 –
1990

AS 60529

AS/NZS 3000:
2000: 1.4.58AS/NZS 3000:
2007: 1.4.61AS/NZS 3000:
2007: G1

Question 9*Marks**Reference**Marking notes*

(ii) Any ONE of:

(2 marks)

- The degree of protection of persons against live or moving parts inside the enclosure
And protection of the fitting against ingress of solid foreign bodies
- Protection against solid objects
- The degree of protection against solid objects
- Protection of persons against access to hazardous parts.
- Protection of against ingress of solid objects.

AS 1939
supplement 1 –
1990

AS 60529

AS/NZS 3000:
2000: 1.4.58AS/NZS 3000:
2007: Table G1(a)

(iii) Any ONE of:

(2 marks)

- Protection of equipment against harmful ingress of water.
- Protection against liquids
- A degree of protection against entry of water with harmful effects.
- Protection of against harmful ingress of water.

AS 1939
supplement 1 –
1990

AS 60529

AS/NZS 3000:
2000: 1.4.58AS/NZS 3000:
2007: Table G1(b)

Question 9*Marks**Reference**Marking notes*(b) **3** Any ONE of:

(1 mark)

- Protection of persons holding tools or wires (larger than 2.5 mm) and protection of equipment against objects larger than 2.5mm².
- Protected against solid objects over 2.5 mm (tools and small wires)
- The access probe of 2.5 mm diameter shall not penetrate.

AS 1939
supplement 1

AS 60529

AS/NZS 3000:
2007: Table G1(a)**4** Any ONE of:

(1 mark)

- Protection against splashing and spraying water from all practicable directions.
- Protection against water sprayed from all directions – limited ingress permitted.
- Protection against water splashed from all directions. Limited ingress permitted.

AS 1939
supplement 1

AS 60529

AS/NZS 3000:
2007: Table G1(b)

Question 9*Marks**Reference**Marking notes*

(c) A situation in which moisture is either permanently present, or intermittently present to such an extent as would be likely to impair the effectiveness or safety of an electrical installation which complies with this Standard for ordinary situations.

(2 marks)

AS/NZS 3000:
2000 1.4.37
2007 1.4.40

Section 3 – Gasfitters Only

Question 10

Marks

Reference

Marking notes

- (a) • Visual check. (5 marks)
• Insulation resistance test.
• Protective earthing conductor test.
• Correct circuit connections (polarity) test.
• Circuit continuity test.
- (b) • To ensure that the control switch is connected in the phase conductor. (1 mark)
- To ensure that the metal framework is connected to the earth pin of the plug. (1 mark)
- To ensure the phase conductor is connected to the phase pin of the plug. (1 mark)
- To ensure the neutral conductor is connected to the neutral pin of the plug. (1 mark)
- (c) Because the IR tester will produce a test voltage of 500V d.c. which will stress the insulation and detect any weakness. (1 mark)

Question 11*Marks**Reference**Marking notes*

- (a) (i) • The motor will operate normally (1 mark)
- The motor circuitry could be live whilst switched off (1 mark)
- (ii) Any ONE of: (1 mark)
- The motor will operate normally
 - The protective earthing conductor is the wrong colour – potential hazard.
- (iii) • The motor will not operate (1 mark)
- Its framework will be alive at 230V to earth (2 marks)
An immediate and serious shock hazard exists.
OR
Could operate the protective device
- (iv) Any ONE of: (1 mark)
- Earth continuity test
 - Polarity test

Question 11*Marks**Reference**Marking notes*

(b) Any THREE of:

(3 marks)

- The wrong isolating switch has been operated.
- The wrong fuses or circuit breakers have been operated.
- The isolating switch is faulty.
- The circuit is being fed from two different sources.
- The isolating switch is not in the Active conductor.

Question 12*Marks**Reference**Marking notes*

(a) (i) The method has to show:

- Identification of the fuse on the switchboard for the boiler. (1 mark)
- Removing the load from circuit and then remove the fuse carrier (1 mark)
- Testing for isolation at the supply side of the permanent connect unit using the prove-test-prove method. (2 marks)

(ii) The method has to show:

- Identification of the correct fuse on the switchboard by a process of elimination. (1 mark)
- Re-testing for isolation at the supply side of the permanent connect unit using the prove-test-prove method. (2 marks)
- Attaching a danger tag to the fuses. (1 mark)

- (b) • Ensure the permanent connection unit cover is securely fixed in place to prevent access to live parts. (2 marks)

Question 13*Marks**Reference**Marking notes*

- (a) The neutral and phase currents are balanced. (1 mark)
- (b) • Neutral current out of balance with the phase current. (1 mark)
- A magnetic field is induced into the iron core. (1 mark)
- The induced magnetic field induces a current in the sensing coil (1 mark)
- The tripping coil is energised, opening the RCD contacts (1 mark)
- (c) RCD (1 mark)
- To ensure the tripping mechanism has not become stuck or "frozen"
- or
- To ensure it works correctly (rapidly)
- or
- PRCD
- To ensure the tripping mechanism has not become stuck or "frozen"
- or
- To ensure PRCD does not reset to the "on" position after supply is re-established.

Question 13*Marks**Reference**Marking notes*

- (d) (i) 300ms or 0.3 seconds (1 mark)
- (ii) 40ms or 0.04 seconds (1 mark)
- (e) PRCDs are voltage dependent to ensure that, when supply is lost:
- Portable or hand-held appliances do not automatically restart when supply is restored. (1 mark)
 - The PRCD has to be manually reset to restore the supply. (1 mark)

Question 14*Marks**Reference**Marking notes*

(a) Any THREE of:

(3 marks)

- TPS cable entering the switch with bare exposed basic insulation.
- Broken switch cover.
- Flexible conduit removed from its clamp.
- Cover off the element thermostat enclosure or not fitted.
- Poor termination of cables
- Cables overheating

(b) Any TWO of:

(2 marks)

- To prevent basic insulation from being exposed.
- To prevent the connections pulling away in the event of strain on the conduit.
- To prevent damage to cables.
- Double insulation is maintained

(c) Any TWO of:

(2 marks)

- There would be exposed live terminals in the fuse base.
- The circuit can be easily relivened by inserting a fuse carrier in the fuse.
- Don't need a tool to reliven.

Question 14*Marks**Reference**Marking notes*

(d) Any THREE of:

(3 marks)

- To prevent basic insulation being exposed
- To prevent live terminals being exposed
- To prevent access to moving parts
- The fitting will not comply with its IP rating