

## 1002- Electrical Service Technician “A” Answer Schedule

Note: (1 mark) means that the preceding statement earns 1 mark.

This schedule sets out the expected answers to the examination questions. The marker can exercise their discretion and decide on the overall adequacy of any answer that is presented in the candidate’s own words.

### Section One

#### Question 1

Highest heating effect

**multi-choice answer – (c)**  
(5 marks)

#### Question 2

0.4A

**multi-choice answer – (a)**  
(5 marks)

#### Question 3

Reverse the connections of the start windings or the run windings

**multi-choice answer – (c)**  
(5 marks)

#### Question 4

A sustained overload

**multi-choice answer – (a)**  
(5 marks)

#### Question 5

Disconnect a large fault current

**multi-choice answer –(a)**  
(5 marks)

**Question 6**

5 metres of  $1.0\text{mm}^2$  cord

**multi-choice answer – (c)**  
(5 marks)

**Question 7**

One element only across the supply

**multi-choice answer –(b)**  
(5 marks)

**Question 8**

Two elements in series

**multi-choice answer – (a)**  
(5 marks)

**Question 9**

Withdraw the appliance plug flexible cord from the socket

**multichoice answer – (c)**  
(5 marks)

**Question 10**

250 volts

**multi-choice answer – (a)**  
(5 marks)

**Section Two****Question 11**

- (a) • Voltage is dropped  
• When forcing the load current  
• Through the conductor resistance (3 marks)
- (b) • By using a flexible cord with an increased cross-sectional area (1 mark)  
• Or reducing the length of the cord (1 mark)

**Question 12**

(a) (i) If strain is applied to the flexible cord the PEC will be the last to pull away from the terminals.

(1 mark)

(ii) Any TWO of:

- The PEC may pull away first.
- Leaving the appliance operational, but unearthed.
- The protection will not operate.

(2 marks)

(b) Any TWO of:

- No guarantee of polarity
- No earthing facility
- Insufficient current rating

(2 marks)

**Question 13**

Any FIVE of:

- If the fuse blows again an arc may be established between the fuse terminals causing damage or injury
- Fuse wire does not have the same Utilisation category (fusing factor) as the HRC fuse
- Cannot safely interrupt short circuit currents of much higher values.
- Fuse wire may protrude past the holder which creates an exposure to shock.
- Suitable fixing for the fuse wire is not generally available.
- Fuse holder is not fire proof.
- Cannot provide "close" protection.
- Cannot ensure reliable operation within prescribed limits.
- Poor discrimination.
- Fusing characteristics not constant.
- Slower operation/acting.
- Deteriorates over time.

(5 marks)

### Question 14

- (a) Current flowing  $I = V \div R$   
 $= 230 \div 18.5$  (1 mark)  
 $= 12.43$  amps fault current would flow (1 mark)
- (b) • The fault current would not operate the fuse. (1 mark)  
 • The heater frame would be alive at 230 volts (1 mark)  
 • The earth fault circuit would overheat due to the  $I^2R$  or  $V^2/R$  of 2859 W (1 mark)

### Question 15

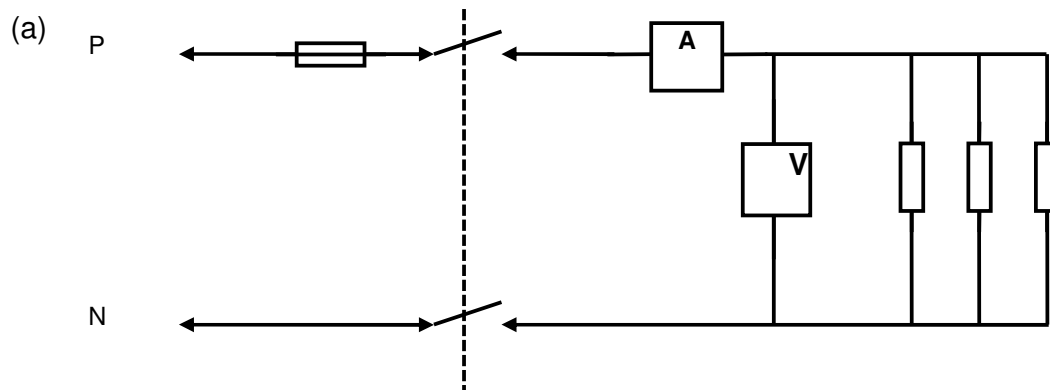

- Correct polarity (½ mark)
  - Correctly connected fuse (½ mark)
  - Correctly connected switch (½ mark)
  - Correctly connected voltmeter (½ mark)
  - Correctly connected ammeter (½ mark)
  - Correctly connected resistors. (½ mark)
- (Total 3 marks)
- (b) (i) 4.6 amps (1 mark)  
 (ii) 1.058 kW or 1058 watts (1 mark)

**Question 16**

- (a) • The voltmeter is a high resistance instrument (1 mark)
- If connected in series with the load resistance it will restrict current flow (2 marks)
- The appliance will not operate (1 mark)
- (b) The highest range of the meter. (1 mark)

**Question 17**

- (a) • It eliminates any residual resistance in the test leads. (1 mark)
- To compensate for variations in the internal battery voltages. (1 mark)
- (b) • Select the appropriate ohm scale to be used. (1 mark)
- Short out the test probes by bringing them together. (1 mark)
- Then adjust the meter to produce a zero reading.  
(Note: but not by adjusting the screw with a screwdriver that is used for re-setting the movement at various meter angles.) (1 mark)

**Question 18**

- (a) An ohmmeter set on the lowest ohms range (2 marks)
- (b) Measure the resistance between the earth pin and the exposed metal of the appliance frame. (2 marks)
- (c) 1 ohm (1 mark)

**Question 19**

- To prevent dangerous voltages occurring. (1 mark)  
Between the exposed metal parts of the two electrical appliances under fault conditions, i.e., when two simultaneous faults occur (2 marks)
- The bonding conductor ensures that a voltage will not exist (1 mark)  
And that sufficient current will flow in the secondary circuit to operate the fuse/s or thermal cut out. (1 mark)

**Question 20**

- (a) Items of apparel and equipment worn by a person that are intended either to prevent the occurrence of harm to the person or to minimise any harm that may occur from hazards that are present in the workplace or hazards that may arise in the course of work  
ER 2  
(1 mark)
- (b) (1) Before beginning the work, to check that any associated equipment and personal protective equipment to be used by that person is in good order and condition, and is safe for its intended use  
ER 36(2)(a)  
(1 mark)
- (2) To use the associated equipment and the personal protective equipment provided in a competent manner.  
ER 36(2)(c)  
(1 mark)
- (c) Any FOUR of:
- Safety glasses or face shield
  - Rubber insulating gloves
  - Apron
  - Safety boots
  - Full body cover overalls
- (2 marks)