

## ESTB 2031 - Electrical Service Technician "B" Answer Schedule

- Notes:1. (1 mark) means that the preceding statement/answer earns 1 mark.
2. This schedule sets out the accepted answers to the examination questions. A marker can exercise their discretion and decide on the overall accuracy of any answer that is presented in the candidate's own words.
3. Symbols and terms - alternatives  
Power W or P  
Voltage V or E or U  
Phase Active
4. Key to abbreviated terms:  
EA Electricity Act 1992  
ER Electricity Regulations 1997  
AS/NZS Australia and New Zealand Joint Standard  
NZS New Zealand Standard  
AS Australian Standard  
ECP New Zealand Electrical Code of Practice  
GK General Knowledge
5. Those parts of an answer that are under-lined indicate the parts required to be covered by a candidate.

### Question 1

- (a) (i) Means that the fittings or appliances are deliberately disconnected from any source of electricity.  
ER2  
(1 mark)
- (ii) Means charged with electricity so that a difference in voltage exists to earth or between conductors  
ER2  
(1 mark)
- (b) (i) When working for payment or reward.  
ER 12(4)  
(1 mark)
- (ii) Within 2 years  
ER Schedule 5 (2)  
(1 mark)
- (c) Any ONE of:
- A supervisor of electrical work whose registration allows that supervisor to do the work
  - A registered person whose registration allows that person to do the work, where the registered person is under the supervision of a supervisor of electrical work whose registration allows that supervisor to do the work  
ER 23(a),(b)  
(2 marks)

- (d) • = 230 – (230 x 5%) (1 mark)  
 = 218.5 V (1 mark)  
 ER53(3)(b)
- (e) (i) Reverse the connections to the start winding.  
 Or  
 Reverse the connections to the run winding. (1 mark)
- (ii) Reverse the connections to the field windings.  
 Or  
 Reverse the connections to the armature windings. (1 mark)
- (f) (i) Zero or nil (1 mark)  
 (ii) 230V (1 mark)
- (g) Any ONE of:
- A coding system to indicate the degree of protection provided by the enclosure against access to live parts from solid objects, or the ingress of water or other liquids  
 AS 1939 supplement 1 – 1990
  - Degrees of enclosure protection for electrical equipment AS 60529
  - A degree of protection in accordance with AS 1939.  
 AS/NZS 3000:2000: 1.4.58  
 AS/NZS 3000:2007: 1.4.61  
 AS/NZS 3000:2007: G1  
 (2 marks)
- (h) (i) Three phase squirrel cage induction motor (1 mark)  
 (ii) A single-phase, split-phase motor (1 mark)
- (i) • Category of duty (Rupturing Capacity)  
 • Utilisation category (fusing factor) (Class) (2 marks)
- (j) • Resistance  
 • Cross-sectional area (2 marks)

## Question 2

(a)(i)

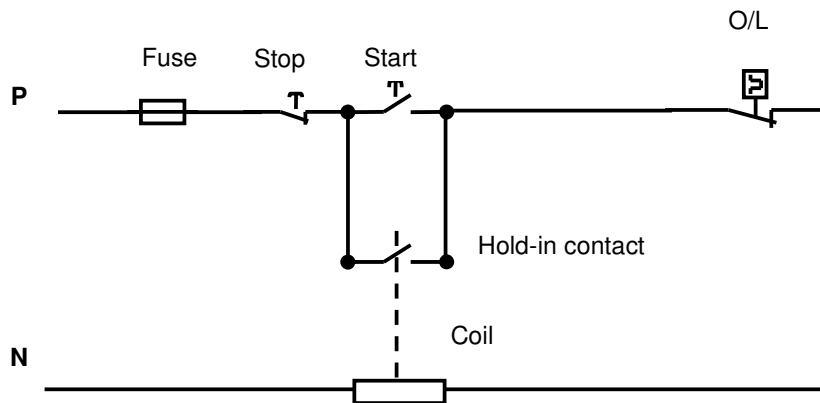

- Correct polarity (phase and neutral) (½ mark)
- Fuse protects the entire circuit (½ mark)
- Stop button controls the entire circuit (except the fuse) (½ mark)
- Start button correctly connected (½ mark)
- Hold-in contacts correctly connected (½ mark)
- Coil correctly connected (½ mark)
- Thermal overload correctly connected (½ mark)
- Working circuit (½ mark)

(ii) (1) Any ONE of:

- A sustained overload or over current.
- The loss of one phase

(1 mark)

(2) A high fault current (short circuit).

(1 mark)

(b) Any TWO of:

- Loss of one phase
- Imbalance in the winding resistance (damaged winding)
- Mechanical damage in the motor (rotor or bearings)
- Increase in load that the motor is driving.

(2 marks)

(c) • Internal connections of one winding reversed  
• Loss of one phase

(2 marks)

### Question 3

(a) The description has to cover:

1. An insulation resistance test showing:
  - the use of an insulation resistance tester (½ mark)
  - a 500V d.c. test voltage (½ mark)
  - testing between phase and earth and neutral and earth (½ mark)
  - an expected test result of 10,000 ohms or 0.01 Mohms (1 mark)
  - the test result being a minimum value (½ mark)
  
2. A protective earthing conductor test showing:
  - the use of a meter that can accurately read values of 1 ohm or less (½ mark)
  - a testing between the PEC conductor of the flexible cord and the case of the cylinder (½ mark)
  - an expected test result of 1 ohm (½ mark)
  - the test result being a maximum value (½ mark)

(b) The procedure has to cover:

- Identifying the correct fuse on the switchboard. (1 mark)
- Attaching a Danger tag to the circuit. (1 mark)
  
- Removing the isolator cover and testing for voltage at the supply side of the isolator using the prove-test-prove method. (2 marks)

#### Question 4

- (a) • That the test meter/instrument - is operating correctly.  
• That the appliance has been isolated before it is worked on. (2 marks)
- (b) Any FOUR of:
- Attach a safety warning tag to the fuse bases
  - Attach a safety warning tag to the isolating switch
  - Lock open the isolating.
  - Disconnect the circuit at the fuses
  - Access permit or "hold card" system. (4 marks)
- (c) • Each conductor must be insulated and made electrically safe.  
• Each conductor should be marked and labelled to permit reconnection to the correct terminals.  
• Mechanical protection of the cables  
• Steps taken to prevent access to the cables. (4 marks)

### Question 5

- (a) • The supply would be short-circuited. (1 mark)
- A personal hazard – flash burns.  
or  
Meter and/or appliance components could be damaged. (1 mark)
- (b) • A 0 volt reading can lead to the false conclusion that the circuit is dead. (1 mark)
- A 0 volt reading will be obtained if the appliance load is open circuited  
(by a switch or element) (1 mark)
- (c) Any FOUR of:
- Inspect instrument, clips, leads and probes to ensure they are in good condition.
  - Don't energise circuit until all connections have been completed.
  - Ensure correct range is selected on the instrument.
  - Ensure leads are correctly connected.
  - Select the correct instrument
- (4 marks)
- (d) Any FOUR of:
- Insulation resistance test
  - Continuity of conductors
  - Verification of polarity
  - Continuity of Earthing
  - Live load test.
  - Correct circuit connections
- (2 marks)

### Question 6

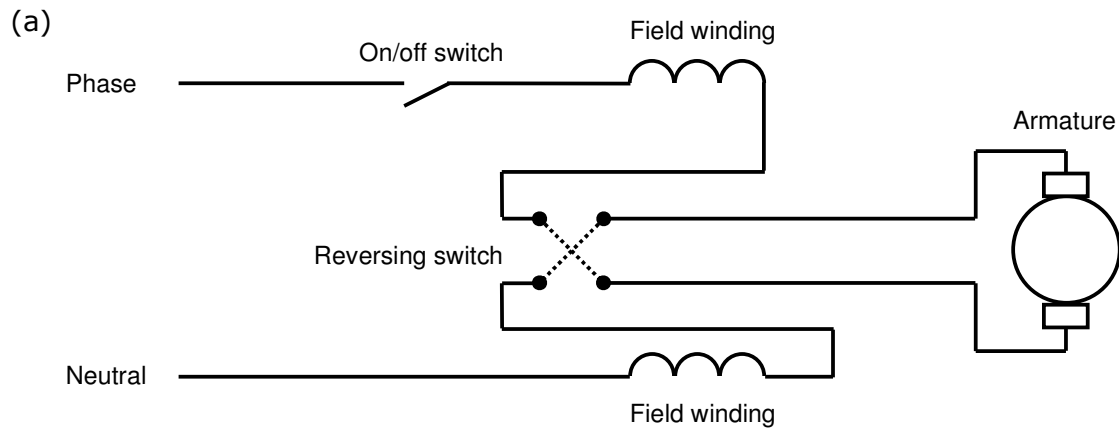

- ½ marks for each correct conductor,
- 1½ marks for correct operation)

(5 marks)

(b) Any TWO of:

- High power-to-weight ratio.
- Maximum torque at zero speed.
- Can be easily speed controlled.
- High speeds available.
- Smaller size
- Lower cost
- Ease of maintenance

(2 marks)

(c) (i)

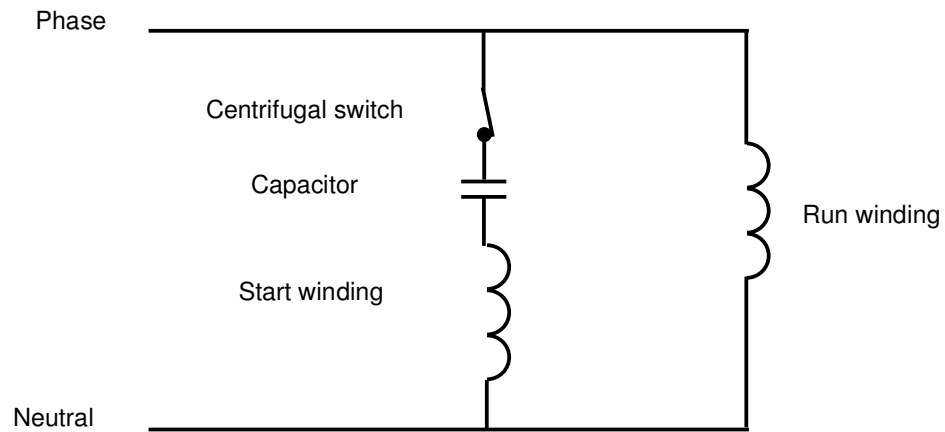

- Correctly connected start winding, capacitor and centrifugal switch (1½ marks)
- Correctly connected run winding (½ mark)

Note: An external relay or electronic device can be used in place of the centrifugal switch.

- (ii) Reverse the connections of the start winding.  
Or  
Reverse the connections of the run winding.

(1 mark)

## Question 7

(a) Yes.

(1 mark)

Both must have a minimum degree of protection of IPX4

AS/NZS 3000:2000:7.1.4.1(b) or Table 7.1

AS/NZS 3000:2007:6.2.4.1(b) or Table 6.1

(1 mark)

(b) (i) Any ONE of:

- A coding system to indicate the degree of protection provided by the enclosure against access to live parts from solid objects, or the ingress of water or other liquids  
AS 1939 supplement 1 – 1990
- Degrees of enclosure protection for electrical equipment  
AS 60529
- A degree of protection in accordance with AS 1939.  
AS/NZS 3000:2000: 1.4.58  
AS/NZS 3000:2007: 1.4.61  
AS/NZS 3000:2007: G1  
(2 marks)

(ii) Any ONE of:

- The degree of protection of persons against live or moving parts inside the enclosure  
And protection of the fitting against ingress of solid foreign bodies  
AS 1939 supplement 1 – 1990
- Protection against solid objects  
AS 60529
- The degree of protection against solid objects
- Protection of persons against access to hazardous parts.  
AS/NZS 3000:2000: 1.4.58
- Protection of against ingress of solid objects.  
AS/NZS 3000:2007: Table G1(a)  
(2 marks)

(iii) Any ONE of:

- Protection of equipment against harmful ingress of water.  
AS 1939 supplement 1 – 1990
- Protection against liquids  
AS 60529
- A degree of protection against entry of water with harmful effects.  
AS/NZS 3000:2000: 1.4.58
- Protection of against harmful ingress of water.  
AS/NZS 3000:2007: Table G1(b)  
(2 marks)

(c) **3** Any ONE of:

- Protection of persons holding tools or wires (larger than 2.5 mm) and protection of equipment against objects larger than 2.5mm<sup>2</sup>.  
AS 1939 supplement 1
- Protected against solid objects over 2.5 mm (tools and small wires)  
AS 60529
- The access probe of 2.5 mm diameter shall not penetrate.  
AS/NZS 3000:2007: Table G1(a)  
(1 mark)

**4** Any ONE of:

- Protection against splashing and spraying water from all practicable directions.  
AS 1939 supplement 1
- Protection against water sprayed from all directions – limited egress permitted.  
AS 60529
- Protection against water splashed from all directions. Limited ingress permitted.  
AS/NZS 3000:2007: Table G1(b)  
(1 mark)

## Question 8

(a)

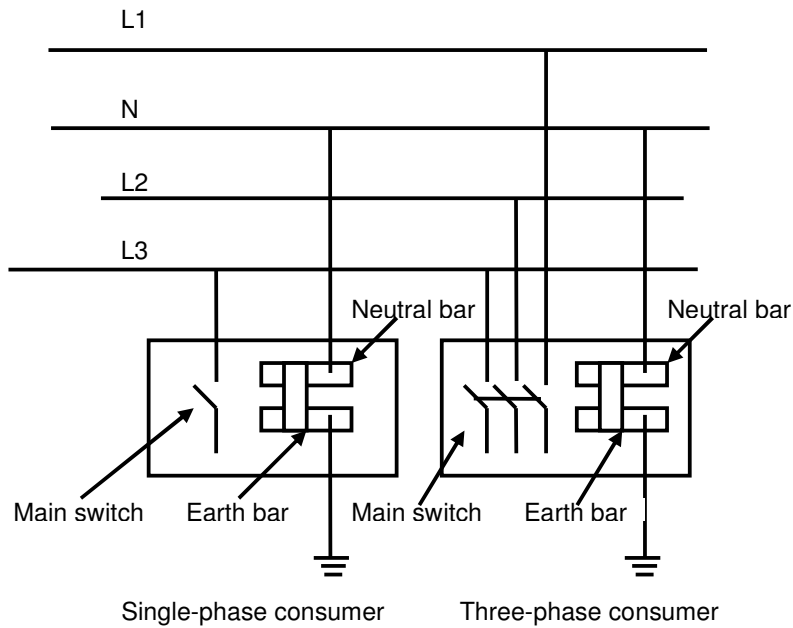

- Supply lines (1 mark)
- Single-phase consumer:
  - main switch (1/2 mark)
  - neutral bar connections. (1/2 mark)
  - earth bar connections. (1/2 mark)
- Three-phase consumer
  - main switch (1/2 mark)
  - neutral bar connections. (1/2 mark)
  - earth bar connections. (1/2 mark)
- Earthing arrangements
  - electrodes (1 mark)
  - links. (1 mark)

(b) Any ONE of:

- To ensure the frame of the motor stay at (or near) earth potential in event of a shock against electric shock by maintaining the machine framework at earth potential.
- To provide a low impedance path that with ensure the protection device operates in the event of a fault.

(2 marks)

(c) Any ONE of:

- The final subcircuit neutral conductor provides the return path from the loads back to the distribution transformer for the resultant "out-of-balance" current from the three phases
- The neutral conductor is required to ensure that the potential across each single phase load is 230V with respect to earth.

(2 marks)

**Question 9**

(a) AS: /N/ZS 3760

(1 mark)

(b)

Type of test	Type of instrument required	Test result
<b>Protective earthing conductor test</b>	<i>Ohmmeter or other instrument with a low reading ohms scale</i>	<b>1 ohm resistance - maximum</b>
<b>Insulation resistance test</b>	<i>Insulation resistance tester</i>	<b>10,000 ohms - minimum</b>

(6 marks)

(c) Any **THREE** of – from AS/NZS 3760:2001:

- Check for obvious damage or defects in the accessories or plugs.
- Check that flexible cords are effectively anchored to equipment and plugs
- Check that the inner cores of flexible supply cords are not exposed or twisted;
- Check that the external sheaths are not cut, abraded, twisted, or damaged to such an extent that the insulation of the inner cores is visible
- Check that unprotected conductors or insulation tape are not in evidence.
- Check that any controls are in good working order i.e. they are secure, aligned and appropriately identified.
- Check that covers, guards and the like are secured in the manner intended by the manufacturer or supplier.
- Check that safety facilities and devices are in good working order.
- Check that ventilation inlets and exhausts are unobstructed.

AS/NZS 3760: 2.3.2

Or

Any **FIVE** of – from AS/NZS 3760:2003:

- Check for obvious damage or defects in the accessories or plugs and for discolouration that may indicate exposure to heat, chemicals and moisture.
- Check that flexible cords are effectively anchored to equipment, plugs and cord extension sockets.

- Check that the inner cores of flexible supply cords are not exposed or twisted;
- Check that the external sheaths are not cut, abraded, twisted, or damaged to such an extent that the insulation of the inner cores is visible
- Check that unprotected conductors or banding insulation tape are not in evidence.
- Check that any operating controls are in good working order i.e. they are secure, aligned and appropriately identified.
- Check that covers, guards and the like are secured in the manner intended by the manufacturer or supplier.
- Check that ventilation inlets and exhausts are unobstructed.
- The pins of insulated pin plugs should be inspected for damage to the insulation of the pins.

AS/NZS 3760: 2.3.2  
(3 marks)