

ESTB 2010- Electrical Service Technician “B” Answer Schedule

- Notes:
1. (1 mark) means that the preceding statement/answer earns 1 mark.
 2. This schedule sets out the expected answers to the examination questions. The marker can exercise their discretion and decide on the overall accuracy of any answer that is presented in the candidate's own words.
 3. Symbols and terms - alternatives
Power W or P
Voltage V or E or U
Phase Active
 4. Key to abbreviated terms:
EA Electricity Act 1992
ER Electricity Regulations 1997
AS/NZS Australia and New Zealand Joint Standard
NZS New Zealand Standard
AS Australian Standard
ECP New Zealand Electrical Code of Practice
GK General Knowledge
 5. Those parts of an answer that are under-lined indicate the parts required to be covered by a candidate.

Question 1

- (a) (i) $W = V^2/R$ (1 mark)
- (ii)
 - The current flow
 - or
 - The power dissipated (1 mark)
- (b) Reverse connections to either start winding or run winding. (2 marks)
- (c) Effectively connected to the general mass of Earth (2 marks)
ER: 2
- (d) Class I – Equipment in which protection against electric shock does not rely on basic insulation only, but in which includes an additional safety precaution in that accessible exposed conductive parts are connected to the protective earthing conductor in the fixed wiring of an electrical installation in such a way that accessible parts cannot become live in the event of failure of the basic insulation.
AS/NZS 3000: 1.4.25
(2 marks)
- (e) 6kA The maximum prospective short circuit current the breaker can safely open under fault conditions. (1 mark)
- 16A Is the nominal current rating of the breaker in normal service. (1 mark)

Question 2

- (a) Interchange any two of the supply phase connections. (2 marks)
- (b) Reverse connections to the field windings or armature windings (or brush-holder connections). (2 marks)
- (c) Any ONE of:
- To protect the fixed wiring against excess current flow
 - Safely interrupt and disconnect a faulty circuit
- (2 marks)
- (d) (i) Decrease (1 mark)
- (ii) Decrease (1 mark)
- (e) Any TWO of:
- Open circuited or short-circuited or faulty capacitor
 - Open circuited centrifugal switch at rest
 - Open start winding circuit
- (2 marks)

Question 3

(a)

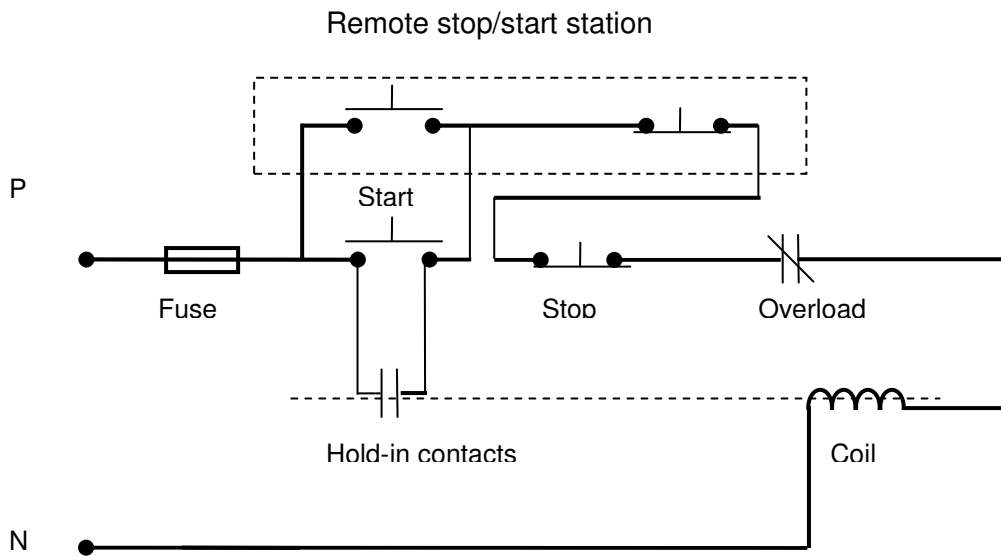

- Correct supply (phase and neutral) (1/2 mark)
- Fuse protecting circuit (1/2 mark)
- Stop/start station correctly connected (1/2 mark)
- Remote stop/start station correctly connected (2 marks)
- Hold-in contacts and coil correctly connected (2 marks)
- Thermal overload contacts correctly connected (1/2 mark)

(b) (i) With an ohmmeter set on the lowest scale, test between each set of terminals in turn until the three lowest resistances between pairs of terminals in known. (2 marks)

(ii)

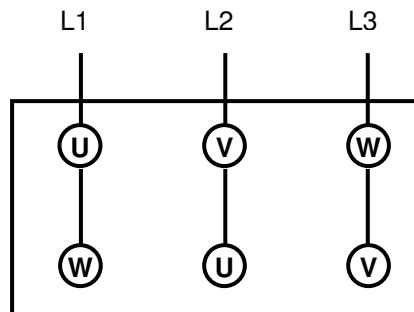

(2 marks)

Note: Any system of terminal identification is acceptable.

Question 4

- (a)
 - Overload caused by too many appliances in use.
 - A faulty appliance
 - A faulty circuit.

(3 marks)

- (b) (i) Overload caused by too many appliances in use.

Action taken to establish that this is the cause

- Total up the rating of appliances from their name-plates

(1 mark)

Remedial action taken or recommended

- Recommend to the supervisor that fewer appliances be used.

(1 mark)

- (ii) A faulty appliance.

Action taken to establish that this is the cause

- Carry out an insulation resistance test of each appliance in turn to establish which is faulty.

(1 mark)

Remedial action taken or recommended

- Repair the faulty appliance or send away for repair.

(1 mark)

- (iii) A faulty circuit.

Action taken to establish that this is the cause

- Isolate circuit at switchboard.
- Carry out an insulation resistance test of the circuit to establish fault.

(1 mark)

(1 mark)

Remedial action taken or recommended

- Recommend to the supervisor that they get an electrician to repair the fault.

(1 mark)

Question 5

(a) (i)

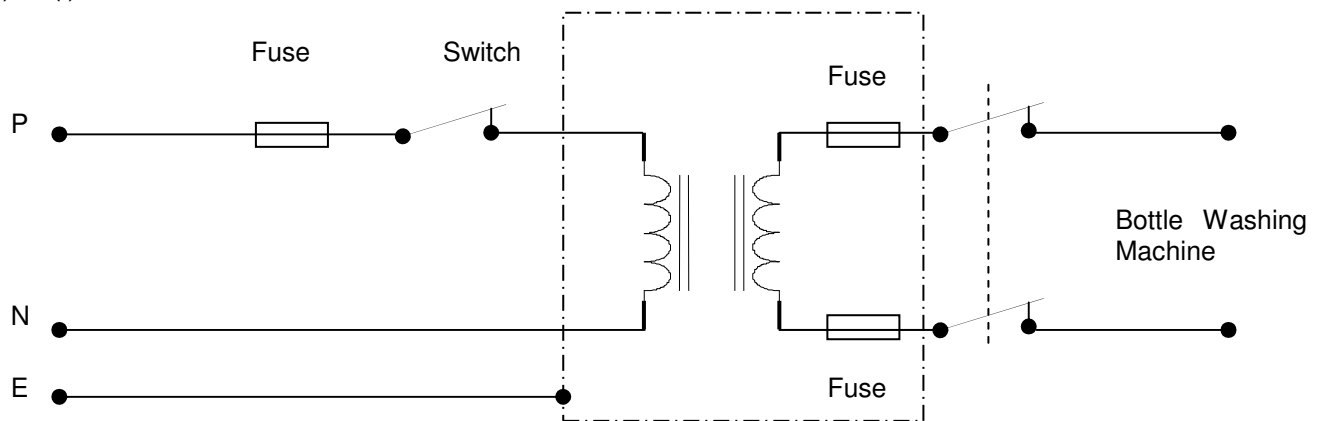

- Correct supply (1½ marks)
 - Primary side fuse is in phase and before the switch (½ mark)
 - Primary side fuse is in phase (½ mark)
 - Transformer correctly represented (1 mark)
 - Fuses in both legs of secondary (½ mark)
 - Fuses before switch in secondary (½ mark)
 - Double pole switch on secondary correctly shown (½ mark)
- (ii)
- The secondary output of the isolating transformer is isolated from earth (1 mark)
 - No danger of shock to earth (1 mark)
- (b)
- To prevent a potential difference occurring between two appliances should a fault or leakage to earth occur.
 - The protection will operate rapidly to disconnect the circuit under fault conditions (3 marks)

Question 6

(a)

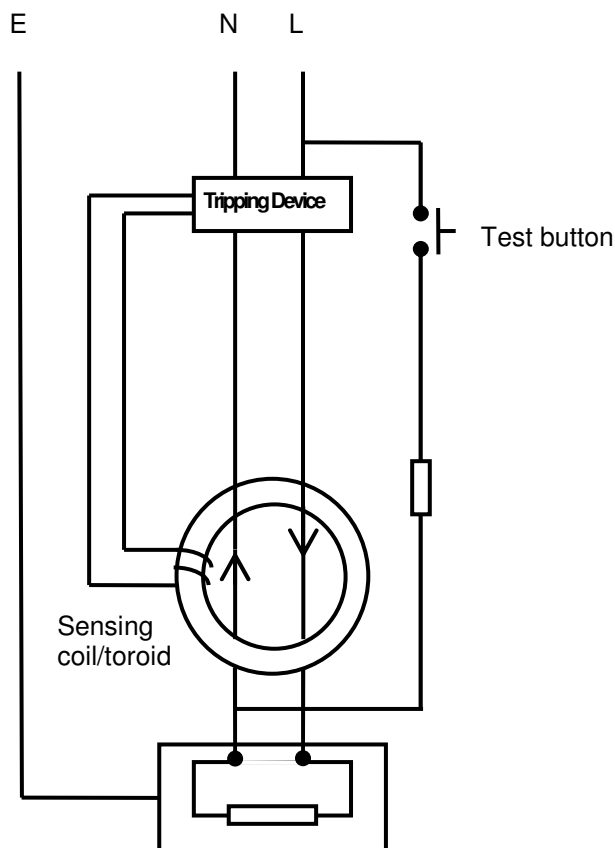

- Correctly connected test circuit and resistance (1 mark)
- Correctly connected sensing coil/toroid (1 mark)
- Correctly connected load (1 mark)
- Correctly connected tripping circuit (1 mark)

(b) (i) 300mS or 0.3 seconds (1 mark)

(ii) 40mS or 0.04 seconds (1 mark)

NZS 3019: 4.8.2.1

- (c)
- When an earth fault occurs, some current is diverted to earth (1 mark)
 - This causes an imbalance between phase and neutral currents (1 mark)
 - Which is detected by the sensing coil. (1 mark)
 - Which trips and disconnects the supply to the load (1 mark)

Question 7

(a) AS: /NZS 3760

(1 mark)

(b)

Type of test	(i) Type of instrument required	(ii) Test result
Earthing continuity	<i>Ohmmeter or other instrument with a low reading ohms scale</i>	<i>Max 1 ohm resistance</i>
Insulation resistance test	<i>Insulation resistance tester</i>	<i>min 10,000 ohms</i>

AS/NZS 3760: Table 2

(c) Any **FIVE** of – from AS/NZS 3760:2001:

- Check for obvious damage or defects in the accessories, connectors, or plugs.
- Check that flexible cords are effectively anchored to equipment and plugs.
- Check that the inner cores of flexible supply cords are not exposed or twisted;
- Check that the external sheaths are not cut, abraded, twisted, or damaged to such an extent that the insulation of the inner cores is visible
- Check that unprotected conductors or insulation tape are not in evidence.
- Check that any controls are in good working order i.e. they are secure, aligned and appropriately identified.
- Check that covers, guards and the like are secured in the manner intended by the manufacturer or supplier.
- Check that safety facilities and devices are in good working order.

AS/NZS 3760: 2.3.2
(5 marks)

Or

Any **FIVE** of – from AS/NZS 3760:2003:

- Check for obvious damage or defects in the accessories, connectors or plugs and for discolouration that may indicate exposure to heat, chemicals and moisture.
- Check that flexible cords are effectively anchored to equipment and plugs.
- Check that the inner cores of flexible supply cords are not exposed or twisted;
- Check that the external sheaths are not cut, abraded, twisted, or damaged to such an extent that the insulation of the inner cores is visible
- Check that unprotected conductors or banding insulation tape are not in evidence.
- Check that any operating controls are in good working order i.e. they are secure, aligned and appropriately identified.
- Check that covers, guards and the like are secured in the manner intended by the manufacturer or supplier.

AS/NZS 3760: 2.3.2
(5 marks)

Question 8

- (a)
- Use an insulation resistance tester (½ mark)
 - Test voltage of 500V d.c (½ mark)
 - Test between each of the three windings. (2 marks)
 - Test between each of the three windings and the motor framework (2 marks)
 - Each test result must be not less than 1 Megohm. (1 mark)
- (b) Disconnect or short circuit the thermistor control circuit before making the insulation resistance test on the windings. (2 marks)
- (c) Ensure that the circuit supply the motor is isolated and tagged.
Or
Isolate and tag the circuit supplying the motor. (2 marks)

Question 9

- (a)
- Switch off the circuit power supply or remove load from circuit and remove fuse carrier. (1 mark)
 - Ensure that there are no exposed terminals in the fuse base. (1 mark)
 - Remove the isolator cover and test for isolation power at the supply side of the isolator using the prove-test-prove method. (2 marks)
 - Lock off isolator and attach danger tag. (2 marks)
- (b)
- Ensure that the exposed cable ends are insulated and safe to touch. (1 mark)
 - Ensure that the cables on the load side of the isolator are protected against mechanical damage. (1 mark)
 - Replace Danger Tag with Out of Service tag. (1 mark)
 - Advise the supervisor that the work is completed and the cylinder is now safe to remove. (1 mark)

Question 10

- (a) • The final subcircuit neutral conductor provides the return path from the loads back to the distribution transformer for the resultant “out-of-balance” current from the three phases (2 marks)
- The neutral conductor is required to ensure that the potential across each single phase load is 230V with respect to earth. (2 marks)
- (b) Any ONE of:
- When the load on each phase is identical and no out of balance current exists
 - Load connected in delta (2 marks)
- (c) “Multiple Earthed Neutral System” or “MEN System” means a system of supply of electricity in which the neutral is connected to earth
- (a) at the source of supply; and
 - (b) at points on the supply system; and
 - (c) at every electrical installation connected to that system. (2 marks)
- Ref: ER 2
- (d) Any TWO of:
- Parallel paths to the star point.
 - Ties the voltage between phase and earth to 230V (standard low voltage).
 - To provide an alternative path to the star point. (2 marks)