

ER 34 - Electrician Regulations Answer Schedule

- Notes: 1. (1 mark) means that the preceding statement/answer earns 1 mark.
2. This schedule sets out the expected answers to the examination questions. The marker can exercise their discretion and decide on the overall accuracy of any answer that is presented in the candidate's own words.
3. Symbols and terms - alternatives
- | | |
|---------|-------------|
| Power | W or P |
| Voltage | V or E or U |
| Phase | Active |
4. Key to abbreviated terms:
- | | |
|--------|--|
| EA | Electricity Act 1992 |
| ER | Electricity Regulations 1997 |
| AS/NZS | Australia and New Zealand Joint Standard |
| NZS | New Zealand Standard |
| AS | Australian Standard |
| ECP | New Zealand Electrical Code of Practice |
| GK | General Knowledge |
5. Those parts of an answer that are under-lined indicate the parts required to be covered by a candidate.

Question 1

- (a) (i) 6% or 13.8V
(ii) 11% or 25.3V
Or
5% or 11.5V

ER 53
(2 marks)

- (b) Must be designed, installed, and set to achieve the maximum practicable sensitivity and minimum practicable operating times in relation to the characteristics of the circuits or other fittings that those fittings protect.

ER 61
(2 marks)

- (c) Any FOUR of:

- An earth electrode
- An earthing lead
- An earth continuity busbar
- Bonding of any available metallic water supply pipes to the earth continuity busbar
- A removable link between the earth continuity busbar and the supply neutral.

ER 86(1)
(2 marks)

(d) Any ONE of:

From AS/NZS 3000:2000

Other circuits including submains and final subcircuits supplying fixed or stationary equipment

AS/NZS 3000:2000 1.7.4.3.4(b)

From AS/NZS 3000:2007

- Other circuits including submains and final subcircuits supplying fixed or stationary equipment

AS/NZS 3000:2007 1.5.5.3(d)

or

- Other circuits where it can be shown that people are not exposed to touch voltages that exceed safe values.

AS/NZS 3000:2007 5.2.2(b)

(2 marks)

- (e) • Avoid danger and to minimise inconvenience in the event of a fault.
• Facilitate safe operation, inspection, testing and maintenance.

AS/NZS 3000:2000: 1.8.5

AS/NZS 3000:2007: 1.6.5

(2 marks)

(f) (i) From AS/NZS 3000:2000: 2.9.8.4(e)

It must be outside or not above any zone

From AS/NZS 3000:2007: 2.9.2.5(e)

It must be outside any classified zone

Note: As an alternative, the actual dimensions from one of the figures in AS/NZS 3000 can be quoted

(1 mark)

(ii) From AS/NZS 3000:2000: 2.9.8.4(h)

It must be suitably protected from the effects of the operation of the sprinkler system which may affect their operation.

From AS/NZS 3000:2007: 2.9.2.5 (j)

It must have a degree of protection of IPX4

(1 mark)

(g) Any TWO of:

- The low voltage cables are of a type providing the equivalent of double insulation; or
- All cables or each conductor of a multicore cable are insulated for the highest voltage present; or
- The low voltage cables are installed in a separate compartment of a common cable trunking system and the compartment has fixed and continuous barriers.

AS/NZS 3000:2000: 3.9.9.3

AS/NZS 3000:2007: 3.9.8.3

(2 marks)

(h) From AS/NZS 3000:2000

Where live parts of electrical equipment or unsheathed cables might come in contact with such metalwork.

AS/NZS 3000:2000: 5.7.3.7

or

- shall be earthed by the connection of a protective earthing conductor to the —
(B) metallic framework or electrical equipment support structure which is in effective electrical contact with the exposed conductive part.

AS/NZS 3000:2000: 5.6.7.5.2(i)(B)

From AS/NZS 3000:2007: 5.4.6.1

Any ONE of:

- Where the risk of contact with live parts of electrical equipment or insulated, unsheathed cables exist.
- Where the double insulation of cables in contact with structural metalwork is not permanently and effectively maintained.

(2 marks)

- (i) (i) 2.7 metres (insulated conductors)
or
4.0 metres (uninsulated conductors)

(ii) 5.5 metres

ECP 34 Table 4
(2 marks)

- (j)
- The earth busbar
 - The earth electrode:

GK
(2 marks)

Question 2

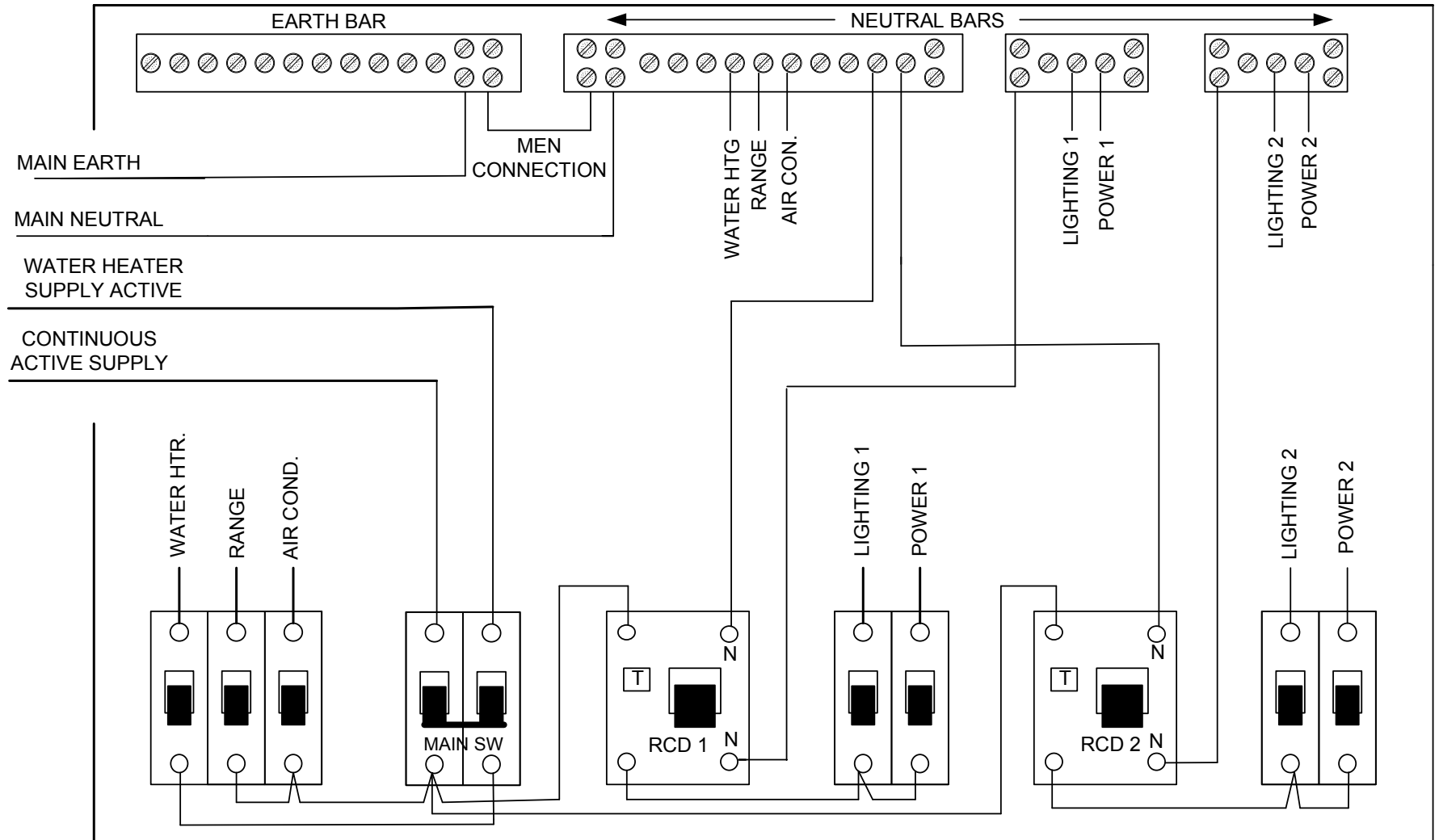

- Correctly connected main earth conductor. (½ mark)
- Correctly connected main neutral conductor. (½ mark)
- Correctly connected MEN link. (½ mark)
- Correctly connected water heater supply active (pilot). (½ mark)
- Correctly connected continuous active supply (the phase). (½ mark)
- Correctly connected supplies to the water heater, range and air conditioning MCBs. (1 mark)
- Correctly connected actives and neutrals for the RCDs. (2 marks)
- Correctly connected supply to lighting 1 and power 1 MCBs. (½ mark)
- Correctly connected supply to lighting 2 and power 2 MCBs. (½ mark)
- Correctly connected neutrals for the lighting 1 and power 1 final subcircuits. (1 mark)
- Correctly connected neutrals for the lighting 2 and power 2 final subcircuits. (1 mark)
- Correctly connected neutrals for the water heater, range and air conditioning final subcircuits. (1½ marks)

Note: The following situations are dangerous:

1. Failure to include the MEN link
2. Switching the neutral via the main switch or an MCB
3. A short circuit anywhere in the switchboard.

No marks are awarded for the entire question if any of these situations are presented

Question 3

(a) Any THREE of:

From AS/NZS 3000:2000: 2.8.3.3.1

- Consumers mains
- Ancillary equipment, measuring devices, and associated wiring provided that this wiring and equipment are confined within or on the switchboard.
- Equipment associated with emergency systems that are connected on the supply side of a main switch
- Equipment associated with alternative supply systems that are connected on the supply side of a main switch
- Fault current limiters.
- Surge diverters installed to protect consumers mains or main switchboards.

From AS/NZS 3000:2007: 2.3.3.1

- Consumers mains
- Equipment installed as required by an electricity distributor for service protection, control or electricity consumption metering purposes
- Ancillary equipment, measuring devices, and associated wiring provided that this wiring and equipment are confined within or on the switchboard.
- Equipment associated with a safety service that is connected on the supply side of a main switch
- Equipment associated with alternative supply system that is connected on the supply side of a main switch
- Fault current limiters.
- Surge diverters installed to protect consumers mains or main switchboards.

(3 marks)

(b) Where supply is provided at more than one point in any building, a prominent notice shall be provided at each main switchboard, indicating the presence of other supplies and the location of other main switchboards.

AS/NZS 3000:2000: 2.8.3.3(d)

AS/NZS 3000: 2007: 2.3.3.4(d)

(2 marks)

(c) From AS/NZS 3000:2000: 2.8.6.1

Functional switching may be used where switching of electrical equipment or part of an electrical installation is required for operational reasons that do not involve safety.

From AS/NZS 3000:2007: 2.3.7.1

Functional switching may be used where switching of electrical equipment or part of an electrical installation is required for operational control only and not for safety reasons.

(2 marks)

(d) From AS/NZS 3000:2000: 2.8.2.2

Any TWO of:

- An earth sheath return (ESR) system.
- Consumers mains.
- A submain where the neutral is used for earthing of an electrical installation in an outbuilding.
- A submain or final subcircuit in which the neutral conductor is solidly earthed.

From AS/NZS 3000:2007: 2.3.2.1.1(b)

- Consumers mains.
- Where the neutral conductor is used as a combined protective earthing conductor and neutral (PEN) conductor for protective earthing of any portion of an electrical installation.

(2 marks)

(e) Any ONE of:

From AS/NZS 3000:2000

- Shall be located and identified in accordance with clauses 2.8.3.3.2, 2.8.3.3.3 and 2.9.8.2
AS/NZS 3000:2000: 2.8.3.3.4(a)
- It shall be provided with a suitable device to enable it to be locked in the open position.
AS/NZS 3000:2000: 2.8.3.3.4(c)
AS/NZS 3000:2007: 2.3.3.5(c)

From AS/NZS 3000:2007

- It shall be located and identified in accordance with clauses 2.3.3.3, 2.3.3.4 and 2.9.2.4
AS/NZS 3000:2007: 2.3.3.5(a)
- It shall isolate supply to the associated parts of the installation.
AS/NZS 3000:2007: 2.3.3.5(b)
- It shall be provided with a suitable device to enable it to be locked in the open position.
AS/NZS 3000:2007: 2.3.3.5(c)(ii)
(1 mark)

Question 4

(a) The allowance for load = $85 \times 15\% = 12.75$ (1/2 mark)

$$85 + 12.75 = 97.75\text{A} \quad (1 \text{ mark})$$

From Table 12, column 14, current rating for a 16 mm^2 cable is 106 amps (buried direct) (1/2 mark)

From Table 27(2) the rating for 20°C is 0.95 (1/2 mark)

$$\text{Therefore, the maximum load} = 106 \times 0.95 \quad (1/2 \text{ mark})$$

$$= 100.7\text{A} \quad (1/2 \text{ mark})$$

A 16 mm^2 cable will satisfy the load current requirements (1 mark)

(b) Maximum permitted voltage drop = $400 \times 1.5\% = 6\text{V}$ (1 mark)

Solution 1

From Table 42 the mV/A.m For a 16 mm^2 cable is 2.43 (1/2 mark)

$$V_d = \frac{\text{mV/A.m} \times A \times m}{1000} \quad (1/2 \text{ mark})$$

$$= \frac{2.43 \times 97.75 \times 17}{1000} \quad (1/2 \text{ mark})$$

$$= 4.04\text{V} \quad (1 \text{ mark})$$

A 16 mm^2 cable will satisfy the voltage drop requirements. (1 mark)

Solution 2

$$V_d = \frac{\text{mV/A.m} \times A \times m}{1000}$$

(½ mark)

$$6 = \frac{\text{mV/A.m} \times 97.75 \times 17}{1000}$$

(½ mark)

$$\text{mV/A.m} = \frac{6 \times 1000}{97.75 \times 17}$$

$$= 3.61 \text{ mV/A.m}$$

(1 mark)

From Table 42 the mV/A.m less than this is for a 16 mm² cable

(½ mark)

A 16 mm² cable will satisfy the voltage drop requirements.

(1 mark)

(c) A 16 mm² cable will satisfy both the load current and voltage drop requirements

(1 mark)

Question 5

(a) (i) From AS/NZS 3000: 2000: 5.5.1.2(c)

(½ mark)

The minimum size of the main earthing conductor shall be determined in accordance with Item (a) and Table 5.1 in relation to the cross-sectional area of the largest active conductor of the consumers mains.

(1½ marks)

From AS/NZS 3000: 2007: 5.3.3.2

The minimum size of the main earthing conductor shall be determined from Table 5.1 in relation to the cross-sectional area of the largest active conductor of the consumers mains.

(ii) 6mm²

(½ mark)

AS/NZS 3000:2000: Table 5.1

AS/NZS 3000:2007: Table 5.1

(½ mark)

(b) From AS/NZS 3000:2000: 5.5.3.1

Any SIX of:

- Aerial conductors.
- Flat braided conductors.
- Busbars.
- Sheaths of MIMS cable.
- Catenary supports.
- Metallic wiring enclosures deemed to be an earthing conductor.
- Copper earthing conductors buried direct in the ground.

From AS/NZS 3000:2007: 5.3.2.4

Any SIX of:

- Aerial conductors.
- Flat braided conductors.
- Busbars.
- Sheaths of MIMS cable.
- Conductive framework and wiring enclosures deemed to be an earthing conductor.
- Copper earthing conductors buried direct in the ground.
- Catenary wires.

(3 marks)

(c) From AS/NZS 3000:2000: 1.7.5.2

- No (½ mark)
- RCDs are not recognized as a sole means of protection against direct contact (in normal service) but may be used to augment one of the means set out in Clause 1.7.3.2. (1 mark)
- Reference AS/NZS 3000:2000: 1.7.5.2 (½ mark)

From AS/NZS 3000:2007: 2.6.1

- No
 - The use of such devices is not recognized as a sole means of protection and does not obviate the need to apply the protective measures specified in clause 2.4.
 - Reference - AS/NZS 3000:2007: 2.6.1.
- (d)
- It shall not be used for the earthing of electrical equipment which is supplied from another switchboard; or
 - It shall not be used for the provision of earthing facilities for another distribution board.

AS/NZS 3000:2000: 5.6.7.3
AS/NZS 3000:2007: 5.5.2.2.2 and 3
(2 marks)

Question 6

- (a) (i) To ensure that the insulation resistance between all live conductors and earth or, as the case may be, all live parts and earth is adequate to ensure the integrity of the insulation.

AS/NZS 3000:2000 6.3.3.3.1
AS/NZS 3000:2007: 8.3.6.1
(2 marks)

- (ii) 1 M Ω

AS/NZS 3000:2000 6.3.3.3.2
AS/NZS 3000:2007: 8.3.6.2
(1 mark)

- (iii) The installation contains appliances with sheathed heating elements and these have been tested to ensure that each had an insulation resistance of not less than 10,000 ohms

AS/NZS 3000:2000 6.3.3.3.2
AS/NZS 3000:2007: 8.3.6.2
(2 marks)

Note: An alternative answer is "a value permitted in the Standard applicable to electrical equipment".

- (b) The test method described for the installation has to show:

- The MEN link and main neutral disconnected. (1 mark)
- All switches and circuit breakers in the "ON" position (1 mark)
- Testing between active (phase) and earth. (1 mark)
- Testing between neutral and earth. (1 mark)
- A minimum insulation resistance for the installation of 1 Megohm (1 mark)

Question 7

(a) Any FOUR of:

- A touch voltage hazard between conductive parts and the mass of earth.
- Protective devices may not operate under fault conditions.
- Fire hazard at any high resistance joint in the main neutral.
- Fire hazard because the main earthing conductor is carrying a higher current than it can safely carry continuously.
- Over or under voltage could damage equipment – particularly on three phase installations.
- Damage could occur on neighbouring electrical installation due to load current passing through the earth.
- Risk of shock in neighbouring properties

GK
(4 marks)

(b) Any TWO of:

From AS/NZS 3000:2000: 4.3.11.1, 2

- A cooking applianceshall be provided with a functional switch, operating in all active conductors, mounted near the appliance in a visible accessible position.
AS/NZS 3000:2000: 4.3.11.1
- The switch should be mounted within 2 m of the cooking appliance, but not on the cooking appliance in such a position that the user does not have to reach across the open cooking surface.
AS/NZS 3000:2000: 4.3.11.1: Note 1
- It is recommended that switches, particularly those in domestic installations, be marked to identify the appliance controlled.
AS/NZS 3000:2000: 4.3.11.1: Note 3
- A cooking appliance shall be connected to the electrical installation wiring by a socket-outlet, that has a suitable current rating
AS/NZS 3000:2000: 4.3.11.2

From AS/NZS 3000:2007: 4.7.1, 2

- A cooking applianceshall be provided with a switch, operating in all active conductors, mounted near the appliance in a visible and readily accessible position.
AS/NZS 3000:2007: 4.7.1
- The switch should be mounted within 2 m of the cooking appliance, but not on the cooking appliance in such a position that the user does not have to reach across the open cooking surface.
AS/NZS 3000:2007: 4.7.1: Note 1
- It is recommended that switches, particularly those in domestic installations, be marked to identify the appliance controlled.
AS/NZS 3000:2007: 4.7.1: Note 3
- A free-standing cooking appliance shall be connected to the electrical installation wiring by a socket-outlet or an installation coupler
AS/NZS 3000:2007: 4.7.2
(2 marks)

(c) From AS/NZS 3000:2000: 4.9.2.2

Any TWO of:

- Where installed in a floor or other horizontal surface, socket-outlets shall be arranged or of such design that dust or water cannot accumulate therein.
- Where installed within 75 mm of a floor, socket-outlets shall be installed so that any plug used with the socket-outlet is withdrawn in the horizontal plane or complies with Item (a).
- Socket-outlets shall be so installed that a plug is not likely to become loose or malfunction due to gravity, vibration or the weight of the flexible cord or cable.

From AS/NZS 3000:2007: 4.4.2.2

Any TWO of:

- Where installed in a floor or other horizontal surface, socket-outlets shall be arranged or of such design that dust or water cannot accumulate therein.
- Where installed within 75 mm of a floor, socket-outlets shall be installed so that any plug used with the socket-outlet is withdrawn in the horizontal plane or complies with Item (a).
- Socket-outlets shall be so installed that a plug is not likely to become loose or malfunction due to gravity, vibration or the weight of the flexible cord or cable.
- Where installed for the connection of a fixed or stationary appliance or a luminaire that is not readily accessible, the socket outlet shall be securely fixed to a structure or support.
- The use of socket outlet is restricted in a number of particular locations, including damp situations.
- Where socket outlets are installed in building surfaces that are required to provide fire-resistance or acoustic properties, measures shall be taken to ensure these properties are maintained.

(2 marks)

(d) Any TWO of

- The gM fuse links will withstand motor starting currents.
- Starting currents up to 7 times full load current.
- The fusing factor (utilisation category) is typically between 1.6 and 2.5

(2 marks)

GK

Question 8

Solution 1

For load group A(i) – Diversity factors from column 2, including the lighting track assessed as per note (d)

Load Group	Calculation	Load (A)	
<u>Group A(i)</u>			
32, 75W indoor lighting points 6 metres of lighting track	$32 + (6 \times 2) = 44$ points $3 + 2 + 2$	7	(1½ marks)
<u>Group A(ii)</u>			
15, 75W outdoor lighting points	$15 \times 75 \times 0.75 = 843.75$ $843.75 \div 230 =$	3.67	(1½ marks)
<u>Group B</u>			
10, Single 10A socket outlets 10, Double 10A socket outlets	$10 + 20 = 30$ outlets	15	(1 mark)
<u>Group C</u>			
10kW range	$(10000 \times 0.5) \div 230 =$	21.74	(1½ marks)
<u>Group F</u>			
3kw controlled water heater	$3000 \div 230 =$	13.04	(1 mark)
<u>Group G</u>			
6kw spa pool	$(6000 \times 0.75) \div 230 =$	19.56	(1½ marks)
Total demand maximum		80.01	(2 marks)

AS/NZS 3000:2000: Table C1
AS/NZS 3000:2007: Table C1

Solution 2

For load group A(i) – The calculation of the connected load from note (f)

Load Group	Calculation	Load (A)	
<u>Group A(i)</u>			
32, 75W indoor lighting points	$32 \times 75 = 2400W$	13.43	(1½ marks)
	$2400 \div 230 = 10.43A$		
6 metres of lighting track	$0.5 \times 6 = 3A$		
<u>Group A(ii)</u>			
15, 75W outdoor lighting points	$15 \times 75 \times 0.75 = 843.75$	3.67	(1½ marks)
	$843.75 \div 230 =$		
<u>Group B</u>			
10, Single 10A socket outlets	$10 + 20 = 30$ outlets	15	(1 mark)
10, Double 10A socket outlets			
<u>Group C</u>			
10kW range	$(10000 \times 0.5) \div 230 =$	21.74	(1½ marks)
<u>Group F</u>			
3kw controlled water heater	$3000 \div 230 =$	13.04	(1 mark)
<u>Group G</u>			
6kw spa pool	$(6000 \times 0.75) \div 230 =$	19.56	(1½ marks)
Total demand	maximum	86.44	(2 marks)

AS/NZS 3000:2000: Table C1
AS/NZS 3000:2007: Table C1

Question 9

(a) Any THREE of:

- To ensure that no shock hazard arises from the incorrect connection of active, neutral and earthing conductors
- To prevent the transposition of active and neutral conductors of the consumers mains or submains (with MEN connection at outbuilding or detached portion) resulting in the electrical installation earthing system becoming energized
- To prevent combinations of incorrect active, neutral and earthing conductor connections resulting in the exposed conductive parts of the electrical installation becoming energized; and
- To prevent the connection of switches in neutral conductors, resulting in parts of appliances, such as heating elements and lampholders, remaining energized when the switches are in the 'OFF' position.

AS/NZS 3000:2000: 6.3.3.4.1

AS/NZS 3000:2007: 8.3.7.1

(3 marks)

(b) (i) Equipment

- Voltage tester
- Temporary earth electrode
- Trailing lead

(1½ marks)

Test method

The test method has to show:

- Installing the remote earth and connecting the trailing lead to it
(½ mark)
- Taking a voltage test between the supply side of the main switch and the trailing lead/remote earth.
(1½ marks)
- Taking a voltage test between the earth neutral bar and the trailing lead/remote earth.
(1½ marks)

(1½ marks)

- (ii) • The reading at the main switch should be about 0 V (½ mark)
- The reading at the neutral/earth bar should be about 230 V. (½ mark)

- (iii) • The reading at the main switch should be about 230 V (½ mark)
- The reading at the neutral/earth bar should be about 0 V. (½ mark)

- Note: 1. The removal of the MEN link with the installation live is hazardous.
2. Parts (ii) and (iii) can only be marked correct if the equipment stated in (b)(i) is also correct.