

ER 24 – Electrician Regulations Answer Schedule

- Notes: 1. (1 mark) means that the preceding statement/answer earns 1 mark.
2. This schedule sets out the expected answers to the examination questions. The marker can exercise their discretion and decide on the overall accuracy of any answer that is presented in the candidate's own words.
3. Symbols and terms - alternatives
Power W or P
Voltage V or E or U
Phase Active
4. Key to abbreviated terms:
EA Electricity Act 1992
ER Electricity Regulations 1997
AS/NZS Australia and New Zealand Joint Standard
NZS New Zealand Standard
AS Australian Standard
ECP New Zealand Electrical Code of Practice
GK General Knowledge
5. Those parts of an answer that are under-lined indicate the parts required to be covered by a candidate.

Question 1

(a) Any FOUR of:

- Registered electricians
- Registered line mechanics
- Registered electrical inspectors
- Registered electrical service technicians
- Persons who are authorised to carry out such work under a provisional licence
- Trainees
- Qualified engineers

EA 108 (2)
(2 marks)

(b)

(i) Voltage minimum **216.2V** maximum **243.8V**

(ii) Frequency minimum **49.25Hz** maximum **50.75Hz**

ER 53(1)(b) and 55
(2 marks)

- (c) • The metal is not fully isolated from both live parts and earth.
 • The metal is located within arm's reach.
 ER 84(2)
 (2 marks)
- (d) • Warrant of electrical fitness or WOEF
 • Certificate of compliance or COC
 ER 97(4)(a),(b)
 (2 marks)
- (e) (i) Red and any colour except Black, Light Blue, Green or Green/Yellow.
 AS/NZS 3000: 3.8.1
 AS/NZS 3000: Table 3.5
 (1 mark)
- (ii) Equipotential bonding conductors shall be identified in the same manner as provided for an earthing conductor, i.e. Green or Green/Yellow combination.
 AS/NZS 3000: 3.8.1
 AS/NZS 3000: Table 3.5
 (1 mark)
- (f) (i) 0.5m
 (ii) 0.3m
 AS/NZS 3000: Table 3.7
 (2 marks)
- (g) Any TWO of:
- Provided with adequate mechanical protection to prevent damage.
 - Provided with an earthed metallic armouring.
 - Provided with an earthed metallic, screen.
 - Provided with an earthed metallic covering.
 - Provided with an earthed metallic enclosure.
 - Protected by an RCD with a maximum rated residual current of 30 mA.
- AS/NZS 3000: 3.9.4.6
- (h) Any TWO of:
- Plugs shall not be able to enter socket outlets of other voltage systems.
 - Socket outlets shall not accept plugs of other voltage systems.
 - Socket outlets shall not have a contact for a protective earthing conductor.
- AS/NZS 3000: 7.7.11
 (2 marks)

(i) Any TWO of:

- A manually operated isolating switch shall be connected on the supply side of the pump motor controller.
AS/NZS 3000: 7.10.9.1
- The isolating switch shall comply with the general requirements of Clause 2.8.
AS/NZS 3000: 7.10.9.1(a)
- The isolating switch shall be installed adjacent to or on the pump motor controller.
AS/NZS 3000: 7.10.9.1(b)
- The isolating switch shall be provided with a device for locking the switch in the closed position.
AS/NZS 3000: 7.10.9.1(c)
- All switches operating in the supply circuit to fire and smoke control equipment, evacuation equipment and lifts shall be clearly identified to indicate the fire and smoke control equipment, evacuation equipment and lifts that they control.
AS/NZS 3000: 7.10.6.1

(j) (i) 4 metres

ECP 34: 5.2.1
(1 mark)

(ii) 1 metre

ECP 34: Table 6
(1 mark)

Question 2

(a) Any THREE of:

Areas:

- That are damp (kitchens and communal bathrooms)
- Where electrical appliances are used outdoors (construction sites)
- Where there is a high risk of damage to electrical appliances and equipment (construction sites)
- Processing areas where the use of water is prevalent (fish processing)

GK
(3 marks)

(b) (i) Any THREE of:

- Where socket-outlets are added to a final subcircuit, provided that the existing subcircuit is not RCD protected.
- Where socket-outlets are added to a final subcircuit, provided that the existing socket-outlets on the circuit are not RCD protected.
- Where points are added to a final subcircuit in a domestic or residential-type area of an electrical installation, provided that the existing final subcircuit is not RCD protected.
- Where socket-outlets or points that are not RCD protected are replaced.
- Where all points on a new final subcircuit are protected by an RCD installed at the first point of that new final subcircuit.
- A socket-outlet or a connecting device installed in accordance with Clause 4.11 (c), for the connection of fixed or stationary electric cooking appliances, such as ranges, ovens or hotplates.

AS/NZS 3000: 2.5.3.1 and 4
(3 marks)

(ii) • Install an SRCD on the first socket outlet on the final subcircuit and protect all socket outlets downstream with the SRCD

(2 marks)

- Install an SRCD on the socket outlet in the bathroom.

(2 marks)
GK

Question 3

- (a) • Automatic disconnection of the supply
• The use of Class II equipment or equivalent insulation
• Electrical separation

AS/NZS 3000: 1.7.4.2
(3 marks)

- (b) (i) By limiting the prospective touch voltage in the event of a fault between a live part and exposed conductive parts

AS/NZS 3000: 1.7.4.3.1
(2 marks)

- (ii) Final subcircuits that supply:

- Socket-outlets having rated currents not exceeding 63 A.
- Hand-held Class I equipment.
- Portable equipment intended for manual movement during use.

AS/NZS 3000: 1.7.4.3.3
(3 marks)

- (c) Live parts are protected by basic insulation and also protected by double or reinforced insulation

AS/NZS 3000: 1.4.2.6
(2 marks)

Question 4

(a) Any ONE of:

- Protection by means of obstacles in accordance with Clause 1.7.3.5.
- Protection by placing out of reach in accordance with Clause 1.7.3.6.

AS/NZS 3000: 7.2.3.1
(1 mark)

(b) • Only the socket outlet for the connection of pool equipment is permitted – AS/NZS 3000: 7.2.4.3(b)

(1 mark)

- This is because both socket outlets are in Zone 1 – AS/NZS 3000: Figure 7.2A

(1 mark)

- Socket outlets that are not intended for the connection of pool equipment are not permitted in Zone 1 – AS/NZS 3000: 7.2.4.3(c)

(1 mark)

(c) (i) IPX5

AS/NZS 3000: 7.2.4.3(b)(i)
(1 mark)

(ii) The socket outlet must be at least 0.45m above ground.

AS/NZS 3000: 7.2.4.3(b)(ii)(A)
(1 mark)

(iii) • Supplied by a residual-current device with a maximum rated residual current of 30 mA; and

AS/NZS 3000: 7.2.4.3(b)(iii)(A)

- Controlled by a switch that does not operate automatically by the insertion or withdrawal of a plug.

AS/NZS 3000: 7.2.4.3(c)
(2 marks)

(d) • Prevent the entry of moisture to any connection

- Prevent water siphoning through any wiring enclosure or cable

AS/NZS 3000: 7.2.4.2
(2 marks)

Question 5

(a) Calculate line current

$$\begin{aligned} I_L &= \frac{100000}{\sqrt{3} \times 400} && (1/2 \text{ mark}) \\ &= 144 \text{ A} && (1 \text{ mark}) \end{aligned}$$

Allowance for future growth $144 \times 15\% = 166\text{A}$ (1 mark)

From Table 12, column 14, rating of 35 mm^2 is 165 A (1/2 mark)

From Tables 27(2) the re-rating factor is 1.04 (1/2 mark)

$$\begin{aligned} I_{\max} &= 166 \times 1.04 \\ &= 173\text{A} \end{aligned} \quad (1 \text{ mark})$$

Based on loading a 35 mm^2 cable is suitable. (1 mark)

(b) Cable size based on volt drop

Maximum volt drop permitted is 7 volts .

From Table 42, $V_d/A.m = 1.11$ for 35 mm^2 cable (1/2 mark)

$$\text{Volt drop} = \frac{V_d/A.m \times I \times L}{1000} \quad (1/2 \text{ mark})$$

$$= \frac{1.11 \times 166 \times 30}{1000} \quad (1/2 \text{ mark})$$

$$= 5.5 \text{ V} \quad (1 \text{ mark})$$

This is below the 7 V max. volt drop permitted.

Based on volt drop a 35 mm^2 cable is suitable. (1 mark)

(c) The 35 mm^2 cable is suitable both in terms of loading and volt drop (1 mark)

Question 6

- (a)
1. Earth resistance test – continuity of main earthing conductor
 2. Insulation resistance test of the installation
 3. Earth resistance test for other earthed equipment and equipotential bonded parts
 4. Consumers mains – polarity
 5. Submains – polarity
 6. Final; subcircuit test – polarity and connections
 7. Fault loop impedance test
 8. verification of operation of RCDs

Numbers 4 to 6 can be in any order.

AS/NZS 3000: Figure 6.1
(4 marks)

- (b) To ensure that the earthing system has been installed in a manner that will cause circuit protective devices to operate if there is a fault between live parts, other than the neutral, and the mass of earth.

AS/NZS 3000: 6.3.3.2.1
(2 marks)

- (c) To ensure that the insulation resistance between all live conductors and earth or, as the case may be, all live parts and earth is adequate to ensure the integrity of the insulation.

AS/NZS 3000: 6.3.3.3.1
(2 marks)

- (d) The installation contained sheathed heating elements and the electrician tested these to ensure that each had an insulation resistance of not less than 10,000 ohms

AS/NZS 3000: 6.3.3.3.1
(2 marks)

Question 7

- (a) • Circuit-breakers incorporating short-circuit and overload releases.
• Circuit-breaker fuse combinations.
• Enclosed fuse links.

AS/NZS 3000: 2.4.2
(3 marks)

- (b) • The switchboard is installed in an area which is accessible only to authorized persons.
• The means of access to such areas is provided with facilities for locking.

AS/NZS 3000: 2.9.6
(2 marks)

- (c) (i) It shall be located within easy access of an entrance to the building.
(1 mark)

- (ii) It shall not be located within any domestic electrical installation.
(1 mark)

AS/NZS 3000: 2.9.8.2

- (d) (i) HRC fuses or backup protection

GK
(1 mark)

- (ii) Thermal overloads

GK
(1 mark)

- (ii) A sustained overload

GK
(1 mark)

Question 8

(a)

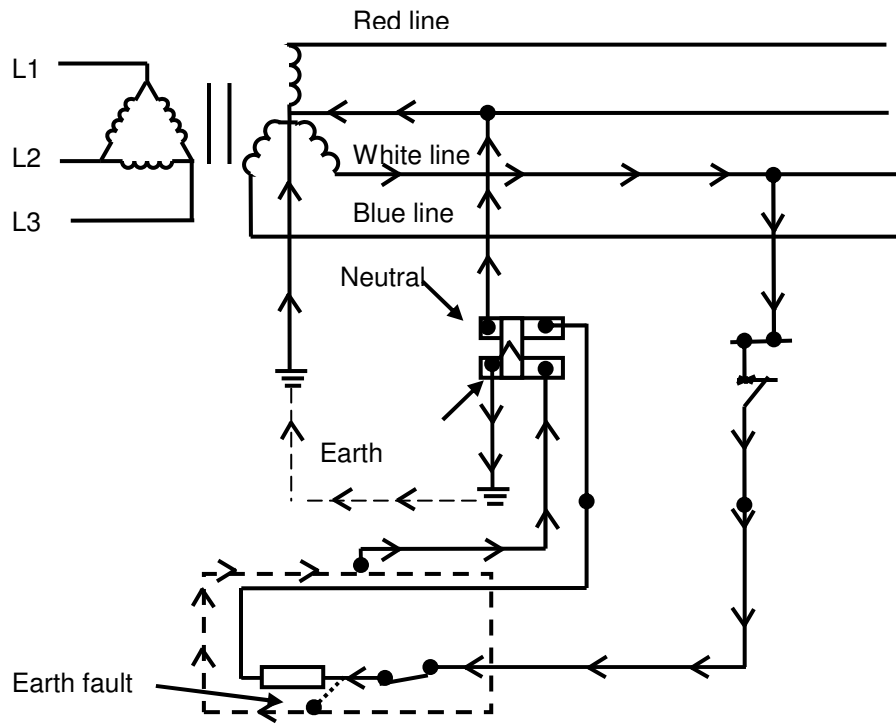

- (i)
- MEN system
 - Star point earthed. (1/2 mark)
 - The consumer's main earth connected to the earth bar. (1/2 mark)
 - MEN link between earth and neutral bars. (1/2 mark)
 - Main neutral connected to consumer's neutral bar. (1/2 mark)
 - Final sub-circuit MCBs in phases or actives (1 mark)
 - Correct distribution system (1 mark)
- (ii) Accurate earth fault loop (1 mark)

Note: The path between the star-point and the installation earth need not be shown. The path via the neutral must be shown.

AS/NZS 3000: B4.3

(b) Any ONE of:

- The fault-loop impedance is low enough to allow sufficient current to flow in the fault loop to cause the protective device to operate within the specified disconnection time.

AS/NZS 3000: B4.2

- In the event of a fault between a live part and an exposed conductive part which could give rise to a prospective touch voltage exceeding 50 V a.c. or 120 V ripple-free d.c., a protective device shall automatically disconnect the supply to the circuit or electrical equipment concerned.

AS/NZS 3000: 1.7.4.3.2

- The characteristics of protective devices and the earthing system impedance shall be such that, if a fault of negligible impedance occurs anywhere in the electrical installation between an active conductor and a protective earthing conductor or exposed conductive part, automatic disconnection of the supply will occur within the specified time.

AS/NZS 3000: 1.7.4.3.3

- The maximum disconnection time for 230/240 V supply voltage shall not exceed the following:

- 0.4 s for final subcircuits
- 5 s for other circuits including submains and final subcircuits

AS/NZS 3000: 1.7.4.3.4

- The resistance from any point on the electrical installation required to be earthed to the point where the main earthing conductor is connected to the neutral conductor of the supply system shall be low enough to permit the passage of current necessary to operate the circuit protective devices.

AS/NZS 3000: 5.343.
(2 marks)

(c) (i) 0.4 seconds

AS/NZS 3000: 1.7.4.3.4
(1 mark)

(ii) 1.53Ω

AS/NZS 3000: Table B4.1
(1 mark)

(iii) 68 metres

AS/NZS 3000: Table B5.1
(1 mark)

Question 9

Load Group	Calculation	Load (A)	
<u>Group A</u>			
Lighting - 20 pts	1 x 3	3	(½ mark)
Lighting - 12 pts	1 x 2	2	(1 mark)
<u>Group B</u>			
10 double	10 x 1	10	(½ mark)
9 single	5 x 1	5	(1 mark)
<u>Group C</u>			
1 kW range	$(10000 \div 230) \times 0.5$	21.7	(1½ marks)
3 kW clothes dryer	$(3000 \div 230) \times 0.5$	6.5	(1½ marks)
<u>Group D</u>			
2.4kw air conditioner	$(2400 \div 230) \times 0.75$	7.8	(1½ marks)
<u>Group E</u>			
6 kW instantaneous water heater	$(6000 \div 230) \times 0.33$	8.6	(1½ marks)
Total maximum demand		64.6	(1 mark)

AS/NZS 3000: Table C1