

ES3 – Security Theory/Regulations Answer Schedule

- Notes:
- (1 mark) means that the preceding statement/answer earns 1 mark.
 - This schedule sets out the expected answers to the examination questions. The marker can exercise their discretion and decide on the overall accuracy of any answer that is presented in the candidate's own words.
 - Symbols and terms - alternatives
Power W or P
Voltage V or E or U
Phase Active
 - Key to abbreviated terms:
EA Electricity Act 1992
ER Electricity Regulations 1997
AS/NZS Australia and New Zealand Joint Standard
NZS New Zealand Standard
AS Australian Standard
ECP New Zealand Electrical Code of Practice
GK General Knowledge

Question 1

- (a) $20 \times 1.5 = 30A$ (2 marks)
- (b) 30 milliamps (2 marks)
- (c) AC80 = Prospective fault current breaking capacity of 80,000 A that the fuse can safely interrupt. (2 marks)
- (d) Any TWO of:
- Capacitors
 - Inductors (chokes)
 - Resistors
- (2 marks)
- (e) Any ONE of:
- Ohmmeters do not apply sufficient voltage to stress the insulation.
 - Does not have an output of 500V d.c. or 250V d.c.
- (2 marks)

Question 2

(a) (i) The current rating is too low for the circuit, and could blow for no apparent reason well below the circuit full-load current. (1 mark)

(ii) The current rating is too large, and the circuit current could increase to a high level causing damage, before the fuse blows. (1 mark)

(b) Any FOUR of:-

- It will safely interrupt short circuit currents of much higher values.
- It eliminates arcing because the fuse element is sealed.
- It is obtainable in a range of Utilisation category (fusing factors).
- Current rating is clearly marked.
- Reliable operation within prescribed limits.
- Good discrimination.
- Constant fusing characteristics.
- Faster operation/acting.
- Doesn't deteriorate over time.

(4 marks)

(c) As current through a fuse or circuit breaker increases beyond its current rating, the time taken to operate decreases.

Note: A drawn representation of the characteristic is acceptable. (2 marks)

(d) Any ONE of:

Thermal

A bi-metal strip bends when heated and trips the circuit breaker out the heating of the strip is caused by the current flowing through it – or through a heater coil.

Electromagnetic

As the current increases, the magnetic field increases, and at a predetermined point, it attracts an armature that trips out the circuit breaker.

(2 marks)

Question 3

(a) Any FOUR of:

- Isolate and tag circuit
- Each conductor must be insulated and made electrically safe.
- Each conductor should be marked and labelled to permit reconnection to the correct terminals.
- Protect the cables to prevent damage
- Take steps to prevent access to the cables.

(4 marks)

(b) Isolation – means deliberately disconnected from the electricity supply and precautions taken to prevent reconnection

Switched off means that the electricity ceases to be supplied to the appliance

(3 marks)

(c) Any THREE of:

- Attach a safety warning tag
- Lock open the isolating switch.
- Lock open the circuit breaker controlling the circuit supplying the security control panel.
- Move the fuse carriers of the fuses controlling the circuit supplying the security control panel to a safe location.
- Use an access permit or “hold card” system.
- Disconnect the circuit supplying the security control panel at source.

(3 marks)

Question 4

(a)

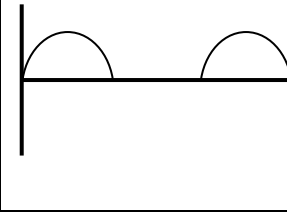
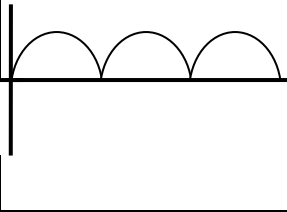
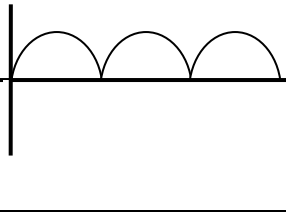
	Single-phase half-wave rectifier	Centre-tapped full-wave rectifier	Single-phase full-wave bridge rectifier
Output waveform			
Ripple frequency	f	2 x f	2 x f

(3 marks)

(b) (i)

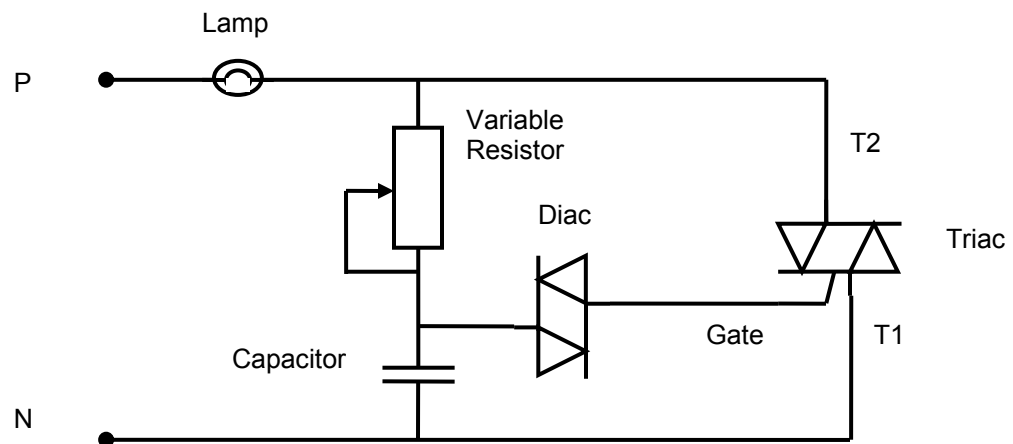

- Correctly connected supply. (½ mark)
- Correctly connected lamp. (½ mark)
- Correctly connected variable resistor. (½ mark)
- Correctly connected capacitor. (½ mark)
- Correctly connected Diac. (½ mark)
- Correctly connected Triac. (½ mark)

(ii)

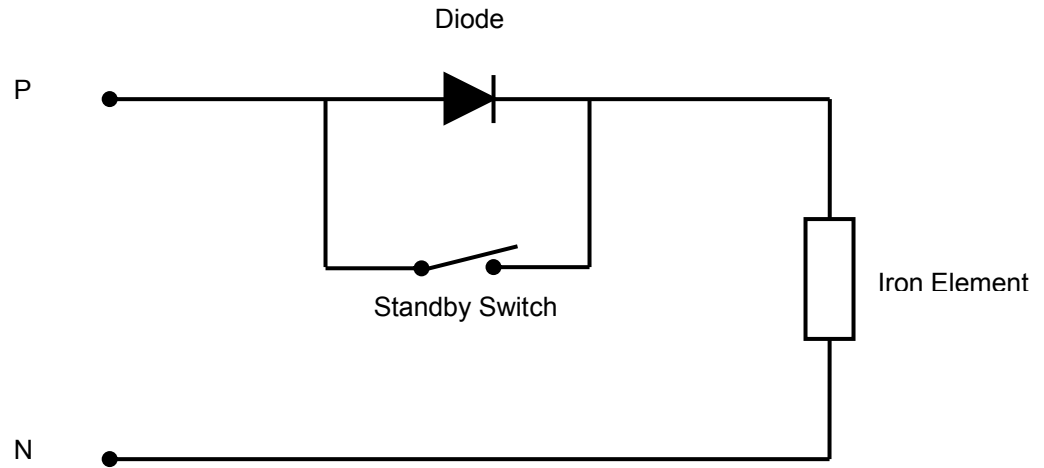

- Correctly connected supply. (½ mark)
- Correctly connected Diode. (½ mark)
- Correctly connected standby switch. (½ mark)
- Correctly connected iron element. (½ mark)

(iii)

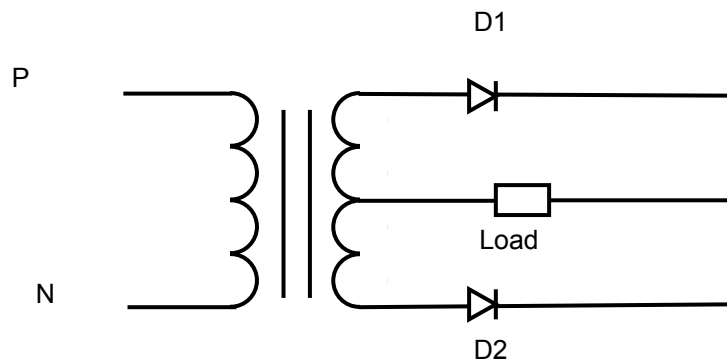

- Correctly connected supply. (½ mark)
- Correctly connected transformer. (½ mark)
- Correctly connected Diodes. (½ mark)
- Correctly connected load. (½ mark)

Question 5

(a) Carrying out a checking or testing procedure with or without test instruments in order to prove that it is safe and has been wired correctly
(2 marks)

(b) (i) Protective earth continuity

- Test between the earth contact on the socket outlet and the switchboard earth bar
- Meter: Low ohmmeter
- Maximum reading: 0.5Ω

(3 marks)

(ii) Insulation Resistance

- Test between all conductors
- Meter: Insulation resistance tester 500V d.c.
- Minimum reading $1M\Omega$

(3 marks)

(iii) Polarity
Check visually and with instruments that all phase conductors are switched and that all conductors go to the right terminals
(1 mark)

(iv) Visual check

Any ONE of:

- No access to live parts without the use of a tool
- Covers are all on
- Connections properly terminated
- Correct colour code
- Labelling at switchboard.

Any other reasonable answers

(1 mark)

Question 6

(a) Any TWO of:

- The person shall be limited to such work as the Board may specify, and in imposing such a limitation the Board may also impose limitations on the circumstances in which that person may do the work.
- The person shall be limited to work only on approved premises.
- The person shall be limited to work only in the employ of an approved employer.

EA 86 (1) (a) (b) (c)
(2 marks)

(b) (i) In relation to fittings or electrical appliances, means that the fittings or appliances are deliberately disconnected from any source of electricity

(ii) Means those fittings forming part of an electrical installation that are used for the supply of electricity to the main switchboard of that installation

ER2
(2 marks)

(c) Any TWO of:

- Shall not be enclosed with the conductors of evacuation equipment and lifts or with conductors of any other system unless approval is obtained from the authorities responsible for the systems.
- If a duct or trunking is divided into separate channels by means of fixed and continuous barriers that provide effective segregation, each channel may be regarded as a separate enclosure.
- Wiring systems complying with Clause 7.10.7.2 may be considered to provide effective segregation.
- Wiring systems within switchboards shall be segregated from all other wiring systems by suitable barriers or a physical separation of at least 50 mm.

(2 marks)
AS/NZS 3000: 7.10.8.1

(d) (i) 1 ohm

AS/NZS 3760
2001: 2.3.3.1
2003: 2.3.3.1
(1 mark)

(ii) 1 Megohm

AS/NZS 3760
2001: 2.3.3.2
2003: Table 2
(1 mark)

(e) Must only be used in, or with, any works, electrical installations or electrical appliances that operate at standard low voltage.

(2 marks)
ER 74(1)(a)

Question 7

(a) (i) Any TWO of:

- Domestic installations
- Residential type areas of residential institutions
- Residential type areas of hotels
- Residential type areas of boarding houses
- Residential type areas of hospitals
- Residential type areas of accommodation houses
- Residential type areas of motels
- Residential type areas of hostels

AS/NZS 3000: 2.5.3.1, 2.5.3.2
(2 marks)

(ii) • Final sub-circuits of socket outlets

AS/NZS 3000: 2.5.3.1, 2.5.3.2

- Final subcircuits of lighting

AS/NZS 3000: 2.5.3.1
(2 marks)

(b) • When an earth fault occurs, some current is diverted to earth (1 mark)

- This causes an imbalance between phase and neutral currents (1 mark)

- Which is detected by the RCD sensing coil. (1 mark)

- Which trips the RCD and disconnects the supply to the load (1 mark)

(c) • Current rating (1 mark)

- Voltage rating (1 mark)

- Category of duty (Rupturing Capacity) (1 mark)

- Utilisation category (fusing factor) (Class) (1 mark)

Question 8

(a) (i) 1 ohm

AS/NZS 3760:2001: 2.3.3.1

AS/NZS 3760:2003: 2.3.3.1

(1 mark)

- (ii) • The resistance to earth from protectively earthed parts in Class I equipment must be low enough to permit adequate fault current to flow to earth thereby ensuring that the overcurrent protective device opens quickly.

AS/NZS 3760:2001: Foreword

or

- To ensure that the resistance of the protective conductor is sufficiently low to ensure the operation of the circuit protecting the equipment.

AS/NZS 3760:2003: 2.3.3.1

(2 marks)

(b) • Disconnect the protective earthing conductor from the security alarm panel and test

(½ mark)

- If the resistance of protective earthing conductor is more than 1 Ω, replace the flexible cord.

(1 mark)

- If the resistance of protective earthing conductor is less than 1 Ω, re-terminate protective earthing conductor, ensuring that the termination is sound and clean.

(1 mark)

- Re-test the protective earthing conductor to ensure resistance is 1 Ω, or less

(½ mark)

(c)

(i) Red

(i) Brown

(ii) Black

(ii) Light Blue

(iii) Green

(iii) Green/Yellow

Accept answers from AS/NZS 3000 or AS/NZS 3760

(3 marks)

(d) Two

(1 mark)

Question 9

- (a) Certificate of compliance (1 mark)
ER 39(1)
- (b) Within 1 day of the completion of the work (1 mark)
ER 39(4)
- (c) (i) The owner of the fittings or the occupier of the premises (1 mark)
ER 40(2)
- (ii) Within 20 working days of completion (1 mark)
ER 40(2)
- (d) (i) 3 years (1 mark)
ER 40(4)
- (ii) To the Board (1 mark)
ER 40(5)
- (e) Any ONE of:
- A registered electrical inspector.
 - A registered electrician.
 - A registered line mechanic.
 - A qualified engineer.
 - A provisional licence holder.
 - A person authorised to certify the prescribed electrical work under an employer licence.
- (1 mark)
ER 39(4)
- (f) (i) Section 6 of AS/NZS 3000 (1 mark)
ER 37(2)
- (ii) After the work is completed and before connection to the supply (2 marks)
ER 37(3)

Question 10

- (a) (1) Safe working practices appropriate to the work being undertaken.
(2) Testing to ensure safety before/during and after completion of the work.
(3) Basic first aid
(4) CPR

ER 26(2)
(2 marks)

- (b) At intervals not exceeding 24 months.

ER 26(3)
(2 marks)

- (c) Must take all practicable steps to:

- Ensure employees are competent to do the work

or

- Are under the supervision of a person competent to do that work

ER 25(3)
(2 marks)

- (d) The owner or occupier of the property and the Secretary of Commerce

ER 50
(2 marks)

- (e) Any TWO of:

- The name of the person so notifying and the place at which that person may be contacted (including where possible a telephone number and facsimile number):
- The place, date, and time of the accident:
- A complete description of the accident:
- A description of any injuries, damage, or losses resulting from the accident:
- Where known, the names and contact information of any witness, investigator at the scene, or other person who could provide cogent information on the accident:
- Possible causative factors (if any are known):
- Any resuscitation applied, including the method, the length of time applied, the reason for discontinuing, and the person that applied the resuscitation:
- Any associated equipment involved, including the type, whether or not it operated correctly, and any reasons why it did not operate correctly:
- The condition of the associated equipment involved, including its age:
- Where known, the name, age, sex, occupation, and residential address of the victim.

ER 106(1)
(2 marks)