

# TEWC 152 - TRADESPERSONS ELECTRICAL WORK CERTIFICATE MARKING SCHEDULE

- Notes: 1. (1 mark) means that the preceding statement/answer earns 1 mark.
2. This schedule sets out the expected answers to the examination questions. The marker can exercise their discretion and decide on the overall accuracy of any answer that is presented in the candidate's own words.
3. Symbols and terms - alternatives  
Power W or P  
Voltage V or E or U  
Phase Active
4. Key to abbreviated terms:  
EA Electricity Act 1992  
ER Electricity Regulations 1997  
AS/NZS Australia and New Zealand Joint Standard  
NZS New Zealand Standard  
AS Australian Standard  
ECP New Zealand Electrical Code of Practice  
GK General Knowledge

## Section 1 – All Candidates

### Question 1

- (a) • 1 M $\Omega$   
or  
10,000 $\Omega$  (1 mark)
- Minimum (1 mark)
- (b) • Safe working practices that are appropriate to the type of work being undertaken.  
• Testing to ensure safety before, during and after work.  
ER 26(2)(a) & (b)  
(2 marks)
- (c) I =  $\frac{W}{V}$  (1/2 mark)
- =  $\frac{1200}{230}$  (1/2 mark)
- = 5.21A (1 mark)

- (d) • Category of duty (Rupturing Capacity).  
• Utilisation category (fusing factor) (Class). (2 marks)

(e) Any **TWO** of:

- High electrical resistance or dielectric strength.
  - Good flexibility.
  - Non absorbent.
  - Withstand mechanical stress.
  - Withstand corrosive environments
  - Withstand the ambient temperature.
  - Withstand heat from the circuit conductors.
  - Abrasion resistance.
- (2 marks)

- (f) It is the maximum fault current that a fuse or circuit breaker can safely interrupt. (2 marks)

(g) 
$$W = \frac{V^2}{R}$$
$$= \frac{230 \times 230}{32}$$
$$= 1653W$$
 (2 marks)

- (h) (i) Closed circuit means a continuous conducting circuit from, and back to, the source of electricity. (1 mark)

- (ii) It is a continuous circuit that has a "break" in it. (1 mark)

- (i) • An isolating transformer  
• An RCD affording personal protection (2 marks)

(j) Any TWO of:

- It prevents the element from bulging out the side of the carrier and being accessible to touch.
  - Under overload conditions the heat produced in the element is confined to the tunnel area.
  - Under short-circuit conditions the arc and molten element is confined within the fuse carrier and base.
  - Allows the fuse carrier to sit properly in the fuse holder
- (2 marks)

## Question 2

(a) The neutral and phase currents are balanced. (1 mark)

(b) • Neutral current out of balance with the phase current. (1 mark)

• A magnetic field is induced into the iron core. (1 mark)

• The induced magnetic field induces a current in the sensing coil (1 mark)

• The tripping coil is energised, opening the RCD contacts (1 mark)

(c) RCD

• To ensure the tripping mechanism has not become stuck or "frozen"  
or

• To ensure it works correctly (rapidly)  
or

PRCD

• To ensure the tripping mechanism has not become stuck or "frozen"  
or

• To ensure PRCD does not reset to the "on" position after supply is re-established. (1 mark)

(d) (i) 300ms or 0.3 seconds (1 mark)

(ii) 40ms or 0.04 seconds (1 mark)

(e) PRCDs are voltage dependent to ensure that, when supply is lost:

• Portable or hand-held appliances do not automatically restart when supply is restored. (1 mark)

• The PRCD has to be manually reset to restore the supply. (1 mark)

### Question 3

(a)

PEC	Green
Neutral	Black
Active (phase)	Red

or

PEC	Green/yellow
Neutral	Light blue or blue
Active (phase)	Brown

**Note:** If the colours in the columns are mixed, the answer is incorrect  
(3 marks)

- (b)
- Minimise the risk of shock.
  - Minimise the risk of short-circuit.
- (2 marks)

(c) Any TWO of:

- Ensure that the flexible cord is securely anchored
- Ensure that the cord grip is on the sheath of the flexible cord, not on the basic insulation.
- Ensure that the basic insulation exposed for the purpose of termination is kept to a minimum

(2 marks)

- (d) If strain is applied to the flexible cord the protective earthing conductor will be the last to pull away from the terminals thereby ensuring the appliance remains earthed

(2 marks)

- (e) It is the maximum current that a flexible cord is designed to carry safely without overheating.

(1 mark)

**Question 4**

(a)

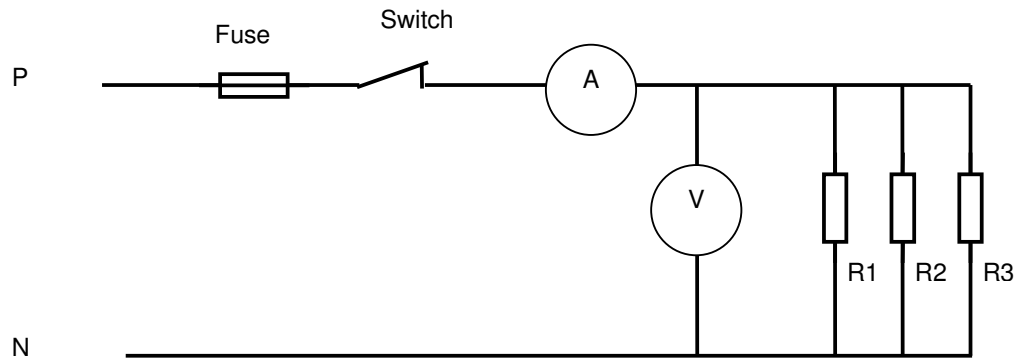

- Correct polarity of the supply (1/2 mark)
- Fuse protects the entire circuit (1/2 mark)
- Switch controls the entire circuit (except the fuse) (1/2 mark)
- Correctly connected voltmeter (1/2 mark)
- Correctly connected ammeter (1/2 mark)
- Correctly connected resistors. (1/2 mark)
- Working circuit (1 mark)

(b) (i)  $I = \frac{V}{R}$  (1/2 mark)

$= \frac{230}{50}$  (1/2 mark)

$= 4.6 \text{ amps}$  (1 mark)

(ii)  $W = VA$  (1/2 mark)

$= 230 \times 4.6$  (1/2 mark)

$= 1058W$  (1 mark)

(iii) 230 volts (1 mark)

(iv) Rise (1 mark)

## Section 2 - Plumbers Only

### Question 5

- (a) (i) The procedure has to cover:
- Identifying and removing the fuse on the switchboard. (1 mark)
  - Attaching a Danger tag to the circuit. (1 mark)
  - Test for isolation at the supply side of the permanent connect unit using the prove-test-prove method. (2 marks)
- (ii) Repeat the procedure set out in the first and third bullet points in (a)(i) until the dishwasher is safely isolated (2 marks)
- (b)
- Ensure the permanent connection unit is securely fixed with no exposed live parts. (1 mark)
  - Replace danger tag with an out of service tag. (1 mark)
- (c) Any TWO of:
- Insulation resistance test
  - Protective earthing conductor test
  - Polarity test
- (2 marks)

## Question 6

(a) (i) Any ONE of:

- A coding system to indicate the degree of protection provided by the enclosure against access to live parts from solid objects, or the ingress of water or other liquids  
AS 1939 supplement 1 – 1990
- Degrees of enclosure protection for electrical equipment  
AS 60529
- A degree of protection in accordance with AS 1939.  
AS/NZS 3000:2000 1.4.58
- A degree of protection in accordance with AS 60529  
AS/NZS 3000:2007 1.4.61  
(2 marks)

(ii) Any ONE of:

- The degree of protection of persons against live or moving parts inside the enclosure  
And protection of the fitting against ingress of solid foreign bodies  
AS 1939 supplement 1 – 1990
- Protection against solid objects  
AS 60529
- The degree of protection against solid objects
- Protection of persons against access to hazardous parts.  
AS/NZS 3000:2000: 1.4.58
- Protection against ingress of solid objects  
AS/NZS 3000:2007: Figure G1a  
(1 mark)

(iii) Any ONE of:

- Protection of equipment against harmful ingress of water.  
AS 1939 supplement 1 – 1990
- Protection against liquids  
AS 60529
- A degree of protection against entry of water with harmful effects.  
AS/NZS 3000:2000 1.4.58
- Protection against harmful ingress of water  
AS/NZS 3000:2007: Figure G1b  
(1 mark)

(b) A **damp situation** is a situation in which moisture is either permanently or intermittently present to such an extent as would be likely to impair the effectiveness or safety of an electrical installation.

(1 mark)

(c) Any FIVE of:

- Replace storage water cylinder heater elements that have an electrical rating of not more than 230 volts and 15 amperes; and
- Replace storage water cylinder thermostats that have an electrical rating of not more than 230 volts and 15 amperes; and
- Disconnect from and reconnect to fixed wiring waste disposal units that have an electrical rating of not more than 230 volts and 15 amperes:
- Disconnect from and reconnect to fixed wiring dishwashing units that have an electrical rating of not more than 230 volts and 15 amperes:
- Disconnect from and reconnect to fixed wiring electronic water control units that have an electrical rating of not more than 230 volts and 15 amperes:
- Disconnect from and reconnect to fixed wiring water pressure devices that have an electrical rating of not more than 230 volts and 15 amperes:
- Disconnect from and reconnect to fixed wiring storage water heater cylinders that have an electrical rating of not more than 230 volts and 15 amperes:
- Remove and replace fusible links in relation to plumbing work.

(5 marks)

ER 49(6)

### Question 7

(a) The procedure has to cover:

- The control switches turned on: (1 mark)
- Bridging the active (phase) and neutral conductors. (1 mark)
- Use of an insulation resistance tester. (½ mark)
- 500V d.c. test voltage (½ mark)
- Testing between the bridged active (phase) and neutral and the appliance frame. (1 mark)
- The result must not be less than 1 MΩ. (1 mark)

(b) To ensure that the insulation will be able to withstand the applied voltage without failure. (2 marks)

(c) Any THREE of:

- Visual inspection
  - Continuity of conductors
  - Continuity of earthing
  - Correct circuit connections (polarity)
- (3 marks)

## Question 8

(a) Any **FOUR** of – from AS/NZS 3760:2001:

- Check for obvious damage or defects in the accessories or plugs.
- Check that flexible cords are effectively anchored to equipment and plugs.
- Check that the inner cores of flexible supply cords are not exposed or twisted;
- Check that the external sheaths are not cut, abraded, twisted, or damaged to such an extent that the insulation of the inner cores is visible
- Check that unprotected conductors or insulation tape are not in evidence.
- Check that any controls are in good working order i.e. they are secure, aligned and appropriately identified.
- Check that covers, guards and the like are secured in the manner intended by the manufacturer or supplier.
- Check that safety facilities and devices are in good working order.
- Check that ventilation inlets and exhausts are unobstructed.

AS/NZS 3760: 2.3.2

Or

Any **FOUR** of – from AS/NZS 3760:2003:

- Check for obvious damage or defects in the accessories or plugs.
- Check for discolouration that may indicate exposure to heat, chemicals and moisture.
- Check that flexible cords are effectively anchored to equipment and plugs.
- Check that the inner cores of flexible supply cords are not exposed or twisted;
- Check that the external sheaths are not cut, abraded, twisted, or damaged to such an extent that the insulation of the inner cores is visible
- Check that unprotected conductors or banding insulation tape are not in evidence.
- Check that any operating controls are in good working order i.e. they are secure, aligned and appropriately identified.
- Check that covers, guards and the like are secured in the manner intended by the manufacturer or supplier.
- Check that ventilation inlets and exhausts are unobstructed.
- The pins of insulated pin plugs should be inspected for damage to the insulation of the pins.

AS/NZS 3760: 2.3.2  
(4 marks)

(b) Test No.1

- (1) Protective earthing conductor (earth continuity) test  
AS/NZS 3760: 2001: 2.3.3.1  
AS/NZS 3760: 2003: 2.3.3.1  
(1 mark)
- (2) Any ONE of:
- Any meter that can accurately read values of less than  $1\Omega$ .
  - An ohmmeter that is of Class 5 accuracy or better
- (1 mark)
- (3) Maximum 1 ohm  
AS/NZS 3760: 2001: 2.3.3.1  
AS/NZS 3760: 2003: 2.3.3.1  
(1 mark)

Test No.2

- (1) Insulation resistance test.  
AS/NZS 3760: 2001: 2.3.3.2  
(1 mark)
- (2) Insulation resistance tester  
AS/NZS 3760: 2001: 2.3.3.2  
AS/NZS 3760: 2001: 2.3.3.2(b)  
(1 mark)
- (3) Not less than  $1\text{ M}\Omega$   
or  
Not less than  $10,000\Omega$   
AS/NZS 3760: 2001: 2.3.3.2(a)  
AS/NZS 3760: 2003: Table 2  
(1 mark)

### Question 9

(a) Any TWO of:

- The wrong isolating switch has been operated.
- The circuit is being fed from two different sources.
- The isolating switch is switching the neutral conductor.

(2 marks)

(b) (i) Most of the internal wiring remains alive at 230V to earth

(1 mark)

(ii) Any TWO of:

- The phase and neutral can be transposed at the plug on the flexible cord.
- The phase and neutral can be transposed at the internal terminals in the appliance.
- The phase and neutral can be transposed in an extension cord supplying the appliance.

(2 marks)

(c) Any TWO of:

- There would be exposed live terminals in the fuse base.
- The circuit can be easily relivened by inserting a fuse carrier in the fuse.
- Don't need a tool to reliven.

(2 marks)

(d) Any THREE of:

- To prevent basic insulation being exposed
- To prevent live terminals being exposed
- To prevent access to moving parts
- To prevent ingress of foreign matter or liquids

(3 marks)

## Section 3 – Gasfitters Only

### Question 10

(a) The procedure has to cover:

- Identifying the fuse on the switchboard. (1 mark)
- Attaching a Danger tag to the circuit. (1 mark)
- Testing for isolation at the supply side of the permanent connect unit using the prove-test-prove method. (2 marks)

(b) Repeat the procedure set out in the first and third bullet points in (a) until the boiler is safely isolated (2 marks)

- (c)
- Ensure the permanent connection unit is securely fixed with no exposed live parts. (1 mark)
  - Replace danger tag with an out of service tag. (1 mark)

(d) Any TWO of:

- Insulation resistance test
  - Protective earthing conductor test
  - Polarity test
- (2 marks)

### Question 11

- (a) (i) • That the test instrument functions correctly.  
• That the circuit to be worked on has been correctly isolated and is safe to work on. (2 marks)
- (ii) • Check that test instrument works correctly on a known live source. (1 mark)  
• Test for isolation (between all conductors) on the circuit being isolated. (1 mark)  
• Check again that test instrument works correctly on a known live source. (1 mark)
- (b) Any TWO of:
- The word "danger" on both sides.
  - The name of the person whose tag it is
  - Identification and location of the equipment being worked on
  - The date the tag was placed. (2 marks)
- (c) • Replace fittings incorporated in gas-fired equipment that have an electrical rating of not more than 230 volts and 15 amperes.  
• Disconnect from and reconnect to fixed wiring, fittings incorporated in gas-fired equipment that have an electrical rating of not more than 230 volts and 15 amperes.  
• Remove and replace fusible links in relation to gasfitting work. (3 marks)  
ER 49(7)

## Question 12

(a) The procedure has to cover:

- The control switches turned on: (1 mark)
- Bridging the active (phase) and neutral conductors. (1 mark)
- Use of an insulation resistance tester. (½ mark)
- 500V d.c. test voltage (½ mark)
- Testing between the bridged active (phase) and neutral and the appliance frame. (1 mark)
- The result must not be less than 1 MΩ. (1 mark)

(b) To ensure that the insulation will be able to withstand the applied voltage without failure. (2 marks)

(c) Any THREE of:

- Visual inspection
- Continuity of conductors
- Continuity of earthing
- Correct circuit connections (polarity)

(3 marks)

### Question 13

(a) Any **FOUR** of – from AS/NZS 3760:2001:

- Check for obvious damage or defects in the accessories or plugs.
- Check that flexible cords are effectively anchored to equipment and plugs.
- Check that the inner cores of flexible supply cords are not exposed or twisted;
- Check that the external sheaths are not cut, abraded, twisted, or damaged to such an extent that the insulation of the inner cores is visible
- Check that unprotected conductors or insulation tape are not in evidence.
- Check that any controls are in good working order i.e. they are secure, aligned and appropriately identified.
- Check that covers, guards and the like are secured in the manner intended by the manufacturer or supplier.
- Check that safety facilities and devices are in good working order.
- Check that ventilation inlets and exhausts are unobstructed.

AS/NZS 3760: 2.3.2

Or

Any **FOUR** of – from AS/NZS 3760:2003:

- Check for obvious damage or defects in the accessories or plugs.
- Check for discolouration that may indicate exposure to heat, chemicals and moisture.
- Check that flexible cords are effectively anchored to equipment and plugs.
- Check that the inner cores of flexible supply cords are not exposed or twisted;
- Check that the external sheaths are not cut, abraded, twisted, or damaged to such an extent that the insulation of the inner cores is visible
- Check that unprotected conductors or banding insulation tape are not in evidence.
- Check that any operating controls are in good working order i.e. they are secure, aligned and appropriately identified.
- Check that covers, guards and the like are secured in the manner intended by the manufacturer or supplier.
- Check that ventilation inlets and exhausts are unobstructed.
- The pins of insulated pin plugs should be inspected for damage to the insulation of the pins.

AS/NZS 3760: 2.3.2  
(4 marks)

(b) Test No.1

- (1) Protective earthing conductor (earth continuity) test  
AS/NZS 3760: 2001: 2.3.3.1  
AS/NZS 3760: 2003: 2.3.3.1  
(1 mark)
- (2) Any ONE of:
- Any meter that can accurately read values of less than  $1\Omega$ .
  - An ohmmeter that is of Class 5 accuracy or better
- (1 mark)
- (3) Maximum 1 ohm  
AS/NZS 3760: 2001: 2.3.3.1  
AS/NZS 3760: 2003: 2.3.3.1  
(1 mark)

Test No.2

- (1) Insulation resistance test.  
AS/NZS 3760: 2001: 2.3.3.2  
(1 mark)
- (2) Insulation resistance tester  
AS/NZS 3760: 2001: 2.3.3.2  
AS/NZS 3760: 2001: 2.3.3.2(b)  
(1 mark)
- (3) Not less than  $1\text{ M}\Omega$   
or  
Not less than  $10,000\Omega$   
AS/NZS 3760: 2001: 2.3.3.2(a)  
AS/NZS 3760: 2003: Table 2  
(1 mark)

### Question 14

(a) Any TWO of:

- The wrong isolating switch has been operated.
- The circuit is being fed from two different sources.
- The isolating switch is switching the neutral conductor.

(2 marks)

(b) (i) Most of the internal wiring remains alive at 230V to earth

(1 mark)

(ii) Any TWO of:

- The phase and neutral can be transposed at the plug on the flexible cord.
- The phase and neutral can be transposed at the internal terminals in the appliance.
- The phase and neutral can be transposed in an extension cord supplying the appliance.

(2 marks)

(c) Any TWO of:

- There would be exposed live terminals in the fuse base.
- The circuit can be easily relivened by inserting a fuse carrier in the fuse.
- Don't need a tool to reliven.

(2 marks)

(d) Any THREE of:

- To prevent basic insulation being exposed
- To prevent live terminals being exposed
- To prevent access to moving parts
- To prevent ingress of foreign matter or liquids

(3 marks)