



(c) Any TWO of

- The appliance is fixed wired and connected through a continuous flexible cord to a supply of electricity from a source isolated from earth with a voltage between conductors not exceeding 250 volts:
- The appliance is supplied with electricity from a safety extra low voltage source:
- The appliance is double-insulated and is supplied with electricity through a residual current device.

ER 77(3)  
(2 marks)

(d) Take a reading with a voltmeter between active and neutral and active and earth.

(2 marks)

(e)  $R = \frac{V^2}{W}$

(1/2 mark)

$$= \frac{230 \times 230}{2300}$$

(1/2 mark)

$$= 23 \Omega$$

(1 mark)

(f) Any TWO of:

- Length of cord
- Cross-sectional area
- Number of cores
- Type of insulation or sheath
- Correct conductor colours

(2 marks)

(g) Any TWO of:

- Building site under construction.
- Outdoor area.
- Factory with concrete floor and steel supports.
- Bathroom or any damp indoor situation.

**Note: The definition of "earthed situation" from AS/NZS 30900 is also acceptable.**

(2 marks)

- (h)
- Voltage applied.
  - Current level .
  - Contact duration.
  - Skin dryness.
  - Current path.

(2 marks)

(i) Any TWO of:

- Insulation resistance test.
- Polarity test.
- Protective earthing conductor (earth continuity conductor) resistance.
- Circuit continuity test.

(2 marks)

(j) An isolating transformer

(2 marks)

## Question 2

(a)

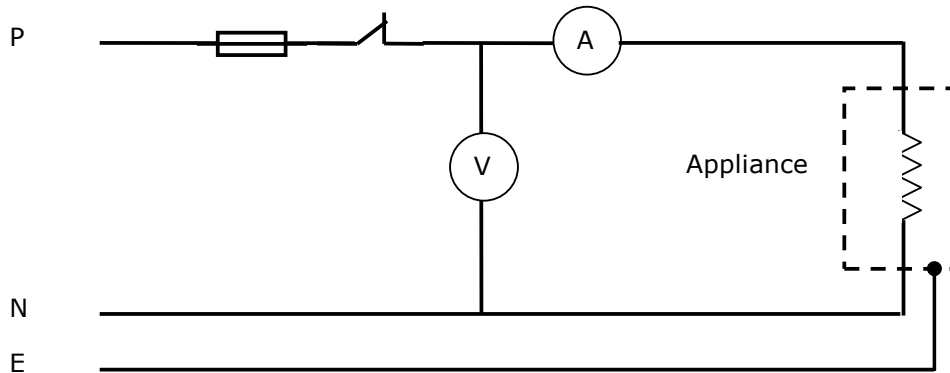

- Correct polarity (1½ marks)
- The fuse protects the whole circuit. (½ mark)
- The single-pole switch controls the whole circuit. (½ mark)
- The voltmeter is in parallel with the appliance on the load side of the switch. (½ mark)
- The ammeter is in series with the appliance and in the phase on the load side of the switch. (½ mark)
- The appliance is earthed (½ mark)

(b)  $R = \frac{V^2}{W}$  (½ mark)

$= \frac{230 \times 230}{1500}$  (½ mark)

$= 35.27 \text{ ohms}$  (1 mark)

(c)  $I = \frac{W}{V}$  (½ mark)

$= \frac{1500}{230}$  (½ mark)

$= 6.52A$  (1 mark)

$$\begin{aligned} \text{(d) } W &= \frac{V^2}{R} \\ &= \frac{240 \times 240}{35.27} \\ &= 1633.11W \end{aligned}$$

(1/2 mark)

(1/2 mark)

(1 mark)

### Question 3

- (a) • Protective earthing conductor test (½ mark)
- Any ONE of:
    - \* Any meter that can accurately read values of less than 1Ω.
    - \* An ohmmeter that is of Class 5 accuracy or better (½ mark)
  - 1Ω (½ mark)
  - Maximum (½ mark)  
AS/NZS 3760: 2001: 2.3.3.1  
AS/NZS 3760: 2003: 2.3.3.1
- Insulation resistance test (½ mark)
- Insulation resistance tester (½ mark)
  - 500 V d.c. (1 mark)
  - 1 MΩ (½ mark)
  - Minimum (½ mark)  
AS/NZS 3760: 2001: 2.3.3.2  
AS/NZS 3760: 2003: 2.3.3.2, Table
- (b) • Not less than 1 MΩ (½ mark)
- AS/NZS 3760: 2001: 2.3.3.3 or Appendix C3  
Or  
AS/NZS 3760: 2003: 2.3.3.3 (½ mark)
- (c) • To ensure that the control switch switches the active conductor.  
• The active pin on the plug is connected to the active terminal in the appliance  
• The neutral pin on the plug is connected to the neutral terminal in the appliance  
• The earth pin on the plug is connected to the frame of the appliance. (4 marks)

#### Question 4

(a) (i) The method has to show:

- Identification of the fuse on the switchboard for the appliance. (1 mark)
- Removing the load from circuit and removing fuse carrier (1 mark)
- Testing for isolation at the supply side of the permanent connect unit using the prove-test-prove method. (2 marks)

(ii) The method has to show:

- Identification of the correct fuse on the switchboard by a process of elimination. (1 mark)
- Re-testing for isolation at the supply side of the permanent connect unit using the prove-test-prove method. (2 marks)
- Attaching a danger tag to the fuses. (1 mark)

(b) • Ensure the permanent connection unit cover is securely fixed in place to prevent access to live parts. (2 marks)

## Section 2 - Plumbers Only

### Question 5

(a) (i) Any ONE of:

- A coding system to indicate the degree of protection provided by the enclosure against access to live parts from solid objects, or the ingress of water or other liquids  
AS 1939 supplement 1 – 1990
- Degrees of enclosure protection for electrical equipment  
AS 60529
- A degree of protection in accordance with AS 1939.  
AS/NZS 3000:2000: 1.4.58
- A degree of protection in accordance with AS 60529.  
AS/NZS 3000:2007: 1.4.61
- A degree of protection of an item of enclosed equipment is expressed as an IP (International Protection) rating in accordance with AS 60529.  
AS/NZS 3000:2007: G1  
(2 marks)

(ii) Any ONE of:

- The degree of protection of persons against live or moving parts inside the enclosure  
And protection of the fitting against ingress of solid foreign bodies  
AS 1939 supplement 1 – 1990
- Protection against solid objects  
AS 60529
- The degree of protection against solid objects
- Protection of persons against access to hazardous parts.  
AS/NZS 3000:2000: 1.4.58
- Protection of against ingress of solid objects.  
AS/NZS 3000:2007: Table G1(a)  
(2 marks)

(iii) Any ONE of:

- Protection of equipment against harmful ingress of water.  
AS 1939 supplement 1 – 1990
- Protection against liquids  
AS 60529
- A degree of protection against entry of water with harmful effects.  
AS/NZS 3000:2000: 1.4.58
- Protection of against harmful ingress of water.  
AS/NZS 3000:2007: Table G1(b)  
(2 marks)

(b) **3** Any ONE of:

- Protection of persons holding tools or wires (larger than 2.5 mm) and protection of equipment against objects larger than 2.5mm<sup>2</sup>.  
AS 1939 supplement 1
- Protected against solid objects over 2.5 mm (tools and small wires)  
AS 60529
- The access probe of 2.5 mm diameter shall not penetrate.  
AS/NZS 3000:2007: Table G1(a)  
(1 mark)

**4** Any ONE of:

- Protection against splashing and spraying water from all practicable directions.  
AS 1939 supplement 1
- Protection against water sprayed from all directions – limited ingress permitted.  
AS 60529
- Protection against water splashed from all directions. Limited ingress permitted.  
AS/NZS 3000:2007: Table G1(b)  
(1 mark)

(c) A situation in which moisture is either permanently present, or intermittently present to such an extent as would be likely to impair the effectiveness or safety of an electrical installation which complies with this Standard for ordinary situations.

AS/NZS 3000:2000 1.4.37  
AS/NZS 3000:2007 1.4.40  
(2 marks)

### Question 6

- (a) (i) • To protect the fixed wiring against excess current flow  
or  
• Safely interrupt and disconnect a faulty circuit (2 marks)
- (ii) To provide personal protection to the user of an appliance that is connected to the circuit protected by the RCD. (2 marks)
- (b) 45A Is the maximum current the fuse can continuously carry (1/2 mark)  
without deterioration. (1/2 mark)
- 440V is the maximum voltage the fuse can withstand (1/2 mark)  
without flashover. (1/2 mark)
- AC40. 40,000AC is the maximum prospective short circuit current (1/2 mark)  
the fuse can safely interrupt (1/2 mark)
- (c) Any TWO of:
- It prevents the fuse element from bulging out the side of the carrier and being accessible to touch.
  - Under overload conditions the heat produced in the element is confined to the tunnel area.
  - Under short-circuit conditions the arc and molten element is confined within the fuse carrier and base.
- (2 marks)
- (d) To disconnect a large fault current safely. (1 mark)

### Question 7

(a) It is the maximum current that a flexible cord is designed to carry safely without overheating.

(1 mark)

(b) The insulation would heat up to a point where it deteriorates and breaks down

(2 marks)

(c) Any FOUR of:

- Number of cores required
- Mechanical strength
- Operating environment
- Flexibility needed
- Application temperature at point of entry to appliance
- Colour coding
- Voltage rating
- Current rating
- Length
- Cross-sectional area

(4 marks)

(d) (i) Two.

(1 mark)

- (ii)
- Phase (active) Brown or Red.
  - Neutral Blue/Light Blue or Black

(2 marks)

### Question 8

(a) (i) Any ONE of:

- To ensure that the resistance of the protective earthing conductor is not greater than 1 ohm.
- To ensure that the earthing systems has been installed in a manner that will cause circuit protective devices to operate if there is a fault between live parts, other than the neutral, and the mass of earth.

(1 mark)

(ii) Any ONE of:

- To ensure that the insulation resistance between active and earth, active and neutral and neutral and earth Is not less than 10,000 ohms.
- To ensure that the insulation resistance between all live conductors and earth and all live parts and earth is adequate.

(2 marks)

(iii) Any ONE of:

- To ensure phase conductor is terminated at the phase terminal  
To ensure neutral conductor is terminated at the neutral terminal  
To ensure the thermostat switches the phase conductor.  
To ensure the protective earthing conductor is connect to the frame of the cylinder.
- To ensure protective earthing conductors do not normally carry current.  
To ensure no short circuit exists  
To ensure no exposed conductive parts become energised.  
To prevent the connection of switches in neutral conductors.

(4 marks)

(b) • The supply would be short-circuited.

(1 mark)

- If the meter protection did not operate:  
A personal hazard – flash burns.  
or  
Meter and/or appliance components could be damaged.

(2 marks)

### Question 9

- (a) (i)
  - That the test instrument functions correctly.
  - That the circuit to be worked on has been correctly isolated and is safe to work on. (2 marks)
- (ii)
  - Check that test instrument works correctly on a known live source. (1 mark)
  - Test for isolation (between all conductors) on the circuit being isolated. (1 mark)
  - Check again that test instrument works correctly on a known live source. (1 mark)
- (b) (i) To ensure an isolated circuit remains isolated until the person who attached the tag changes the status of the circuit. (1 mark)
- (ii)
  - The word "danger" on both sides.
  - The name of the person whose tag it is
  - Identification and location of the equipment being worked on
  - The date the tag was placed. (2 marks)
- (iii) In any situation where you need to ensure that the isolated equipment (or circuit) that you are working on remains isolated (2 marks)

## Section 3 – Gasfitters Only

### Question 10

(a) Any THREE of:

- TPS cable entering the switch with bare exposed basic insulation.
- Broken switch cover.
- Flexible conduit removed from its clamp.
- Cover off the element thermostat enclosure or not fitted.
- Poor termination of cables
- Cables overheating

(3 marks)

(b) Any TWO of:

- To prevent basic insulation from being exposed.
- To prevent the connections pulling away in the event of strain on the conduit.
- To prevent damage to cables.
- Double insulation is maintained

(2 marks)

(c) Any TWO of:

- There would be exposed live terminals in the fuse base.
- The circuit can be easily relivened by inserting a fuse carrier in the fuse.
- Don't need a tool to reliven.

(2 marks)

(d) Any THREE of:

- To prevent basic insulation being exposed
- To prevent live terminals being exposed
- To prevent access to moving parts
- The fitting will not comply with its IP rating

(3 marks)

### Question 11

- (a) (i) • To protect the fixed wiring against excess current flow  
or  
• Safely interrupt and disconnect a faulty circuit (2 marks)
- (ii) To provide personal protection to the user of an appliance that is connected to the circuit protected by the RCD. (2 marks)
- (b) 45A Is the maximum current the fuse can continuously carry (1/2 mark)  
without deterioration. (1/2 mark)
- 440V is the maximum voltage the fuse can withstand (1/2 mark)  
without flashover. (1/2 mark)
- AC40. 40,000AC is the maximum prospective short circuit current (1/2 mark)  
the fuse can safely interrupt (1/2 mark)
- (c) Any TWO of:
- It prevents the fuse element from bulging out the side of the carrier and being accessible to touch.
  - Under overload conditions the heat produced in the element is confined to the tunnel area.
  - Under short-circuit conditions the arc and molten element is confined within the fuse carrier and base.
- (2 marks)
- (d) To disconnect a large fault current safely. (1 mark)

### Question 12

(a) It is the maximum current that a flexible cord is designed to carry safely without overheating.

(1 mark)

(b) The insulation would heat up to a point where it deteriorates and breaks down

(2 marks)

(c) Any FOUR of:

- Number of cores required
- Mechanical strength
- Operating environment
- Flexibility needed
- Application temperature at point of entry to appliance
- Colour coding
- Voltage rating
- Current rating
- Length
- Cross-sectional area

(4 marks)

(d) (i) Two.

(1 mark)

- (ii)
- Phase (active) Brown or Red.
  - Neutral Blue/Light Blue or Black

(2 marks)

### Question 13

(a) (i) Any ONE of:

- To ensure that the resistance of the protective earthing conductor is not greater than 1 ohm.
- To ensure that the earthing systems has been installed in a manner that will cause circuit protective devices to operate if there is a fault between live parts, other than the neutral, and the mass of earth.

(1 mark)

(ii) Any ONE of:

- To ensure that the insulation resistance between active and earth, active and neutral and neutral and earth Is not less than 10,000 ohms.
- To ensure that the insulation resistance between all live conductors and earth and all live parts and earth is adequate.

(2 marks)

(iii) Any ONE of:

- To ensure phase conductor is terminated at the phase terminal  
To ensure neutral conductor is terminated at the neutral terminal  
To ensure the thermostat switches the phase conductor.  
To ensure the protective earthing conductor is connect to the frame of the cylinder.
- To ensure protective earthing conductors do not normally carry current.  
To ensure no short circuit exists  
To ensure no exposed conductive parts become energised.  
To prevent the connection of switches in neutral conductors.

(4 marks)

(b) • The supply would be short-circuited.

(1 mark)

• If the meter protection did not operate:

A personal hazard – flash burns.

or

Meter and/or appliance components could be damaged.

(2 marks)

### Question 14

- (a) (i) Three (1 marks)
- (ii) • Brown, light blue (or blue) and green/yellow  
or  
• Red, black, green (3 marks)
- (iii) Two (1 marks)
- (iv) • Brown and light blue (or blue)  
or  
• Red and black (2 marks)
- (b) (i) If strain is applied to the flexible cord the protective earthing conductor (earth continuity conductor) will be the last to pull away from the terminals. (1 mark)
- (ii) If all conductors are the same length, the earth may pull away first leaving the appliance operational but unearthed. (2 marks)