

ET 28 - Electrician Theory Examination Marking Schedule

- Notes:
- (1 mark) means that the preceding statement/answer earns 1 mark.
 - This schedule sets out the accepted answers to the examination questions. A marker can exercise their discretion and decide on the overall accuracy of any answer that is presented in the candidate's own words.
 - Symbols and terms - alternatives
Power W or P
Voltage V or E or U
Phase Active
 - Key to abbreviated terms:
EA Electricity Act 1992
ER Electricity Regulations 1997
AS/NZS Australia and New Zealand Joint Standard
NZS New Zealand Standard
AS Australian Standard
ECP New Zealand Electrical Code of Practice
GK General Knowledge
 - Those parts of an answer that are under-lined indicate the parts required to be covered by a candidate.

QUESTION 1

- (a) (i) A thermistor is a device which changes resistance with temperature
Note: They can either be n.t.c. or p.t.c. (1 mark)
- (ii) It would be located in the windings of the motor (1 mark)
- (b) Any TWO of:
- Fire hazard due to fittings or cables overheating
 - Flash over on switchboards due to inadequate rating of protective devices
 - Personal injury if people are in the vicinity of failing fittings or cables.. (2 marks)
- (c) $235 \times 12 = 2820\text{VA}$ (1/2 mark)
- $= \frac{2115 \text{ W}}{2820 \text{ VA}}$ (1/2 mark)
- $= 0.75$ (1 mark)
- (d) 40 ms (2 marks)

- (e) (i) The copper shading ring (1 mark)
- (ii) Turn the motor or rotor around (1 mark)
- (f) The difference between the synchronous speed and the rotor speed. (2 marks)
- (g) (i) This is the maximum current that the fuse is designed to carry continuously (1 mark)
- (ii) The maximum fault current the fuse can safely interrupt. (1 mark)
- (h) Any TWO of:
- Improved power factor
 - Quieter running
 - Better running torque
 - Less current drawn
- (2 marks)
- (i) Any TWO of:
- More efficient - less power loss.
 - Smoother starting - less wear and tear on the motor.
 - Easier to adjust for overcurrent and other parameters.
 - Power factor very high because of d.c. bus
 - Visual feed-back through display panels.
 - Physical size smaller than auto-transformer.
 - More economical to maintain – less equipment involved.
 - Reduces mechanical shock to equipment
 - Constant current flow
 - Constant torque
 - Torque is very constant at start
 - Cheaper in the larger sizes
 - Built in protection and monitoring
- (2 marks)

(j) About 1800W

(2 marks)

Or

$$\begin{aligned} & (218.5 \div 230)^2 \times 2000 \\ & = 1805W \end{aligned}$$

Or

$$\begin{aligned} & (0.95)^2 \times 2000 \\ & = 1805W \end{aligned}$$

QUESTION 2

(a) The elements of the fault loop being tested are:

- The socket outlet
- The final subcircuit earth conductor
- The MEN connection
- The consumers main neutral
- The distribution neutral
- The distribution transformer
- The distribution active (phase) conductor
- The main switch
- The switchboard cables
- The protective device
- The final subcircuit active conductor

(5½ marks)

All elements of the fault loop stated

(1½ marks)

(b) Any TWO of:-

- Determine the prospective short circuit current at the point in an installation
- Determine that the correct type and current rating of circuit protection is installed
- Determine the fault loop impedance of the circuit

(2 marks)

(c) It is considered to be the path with the lowest impedance.

(1 mark)
GK

QUESTION 3

(a)

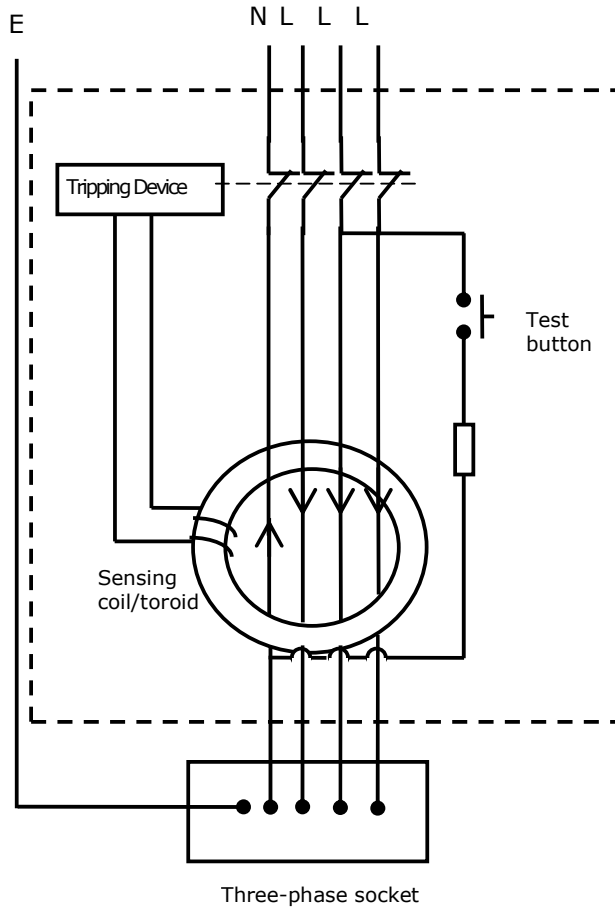

- Correctly connected phases, neutral and earth. (1½ marks)
- Correctly connected test button and resistance (½ mark)
- Correctly connected sensing coil/toroid (½ mark)
- Correctly connected tripping circuit (½ mark)
- Correctly connected socket (½ mark)
- Working circuit (1½ marks)

- (b) • Neutral current out of balance with the phase current. (1 mark)
- A magnetic field is induced into the iron core. (1 mark)
- The induced magnetic field induces a current in the sensing coil (1 mark)
- The tripping coil is energised, opening the RCD contacts (1 mark)
- (c) RCBO **R**esidual **C**urrent-Operated **C**ircuit **B**reaker with **O**vercurrent Protection (1 mark)

QUESTION 4

(a) (i) Red phase current

$$\begin{aligned} I &= \frac{P}{V} && \text{(1/2 mark)} \\ &= \frac{30000}{230} && \text{(1/2 mark)} \\ &= 130.4\text{A} && \text{(1 mark)} \end{aligned}$$

White phase current

$$\begin{aligned} I &= \frac{P}{V} \\ &= \frac{20000}{230} && \text{(1/2 mark)} \\ &= 86.9\text{A} && \text{(1 mark)} \end{aligned}$$

Blue phase current

$$\begin{aligned} I &= \frac{P}{V} \\ &= \frac{10000}{230} && \text{(1/2 mark)} \\ &= 43.5\text{A} && \text{(1 mark)} \end{aligned}$$

(ii) Total 3 phase power,

$$\begin{aligned} P &= R+W+B \\ &= 30\text{kW} + 20\text{kW} + 10\text{kW} \\ &= 60\text{kW} && \text{(1 mark)} \end{aligned}$$

(iii)

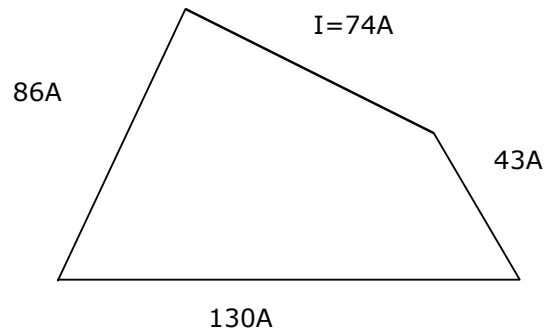

- $\frac{1}{2}$ mark for each correct current (2 marks)
- $I = 74A$ (accept any answer between 72 and 76A) (1 mark)

(b) Any ONE of:

- Minimises outage or overload on highest loaded phase
- Reduces voltage drop on highest loaded phase and on neutral
- Eliminates overheating of components or fittings
- Reduces capacity of individual components of the supply.
- Reduces the neutral current (1 mark)

QUESTION 5

(a)

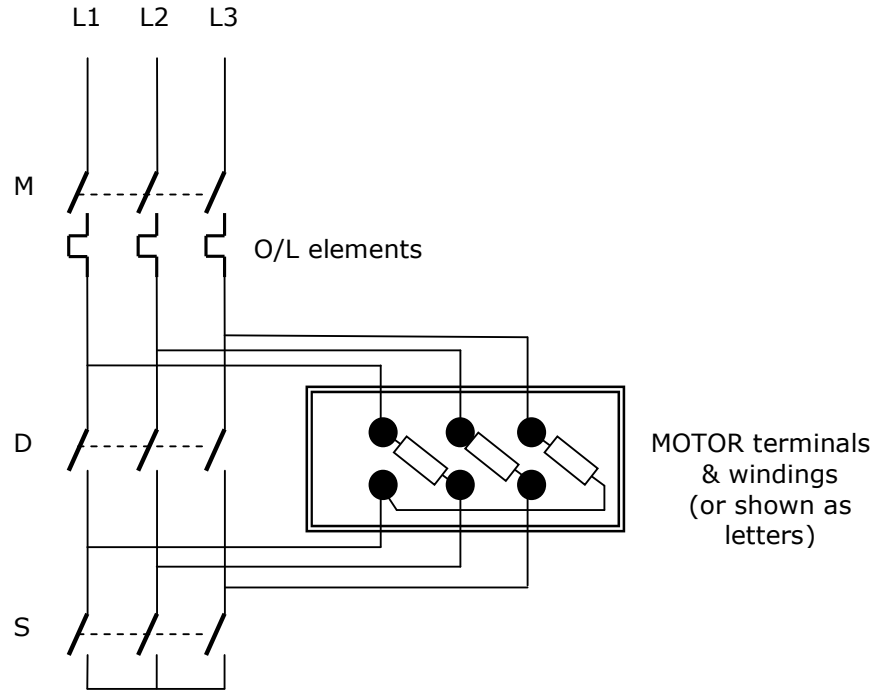

- Correctly connected supply lines (½ mark)
- Correctly connected star contactor (½ mark)
- Correctly connected delta contactor (½ mark)
- Correctly connected overloads. (½ mark)
- Correctly connected motor terminal block (½ mark)
- Correctly connected conductors – that is, a working circuit (2½ marks)

(b)

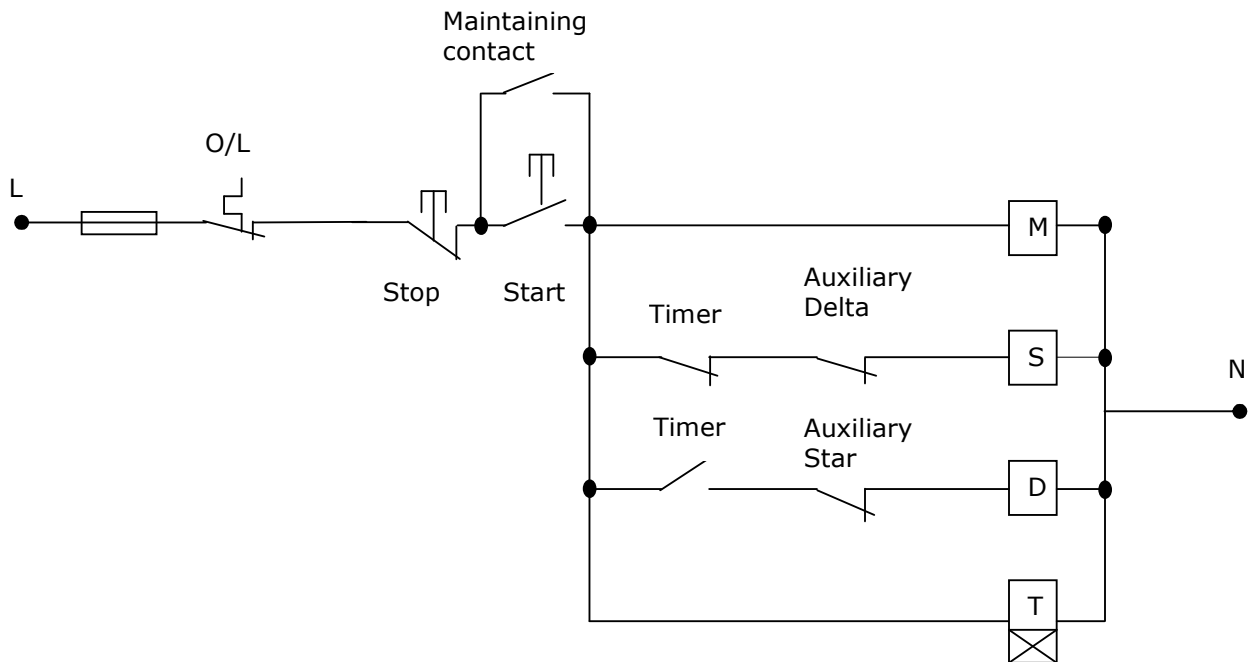

- Correctly connect supply (1/2 mark)
- Correctly connected stop button (1/2 mark)
- Correctly connected start button and hold-in contacts (1/2 mark)
- Correctly connected overload (1/2 mark)
- Correctly connected auxiliary contacts - star (1/2 mark)
- Correctly connected auxiliary contacts - delta (1/2 mark)
- Correctly connected coil - star (1/2 mark)
- Correctly connected coil - delta (1/2 mark)
- Working circuit (1 mark)

QUESTION 6

(a) Any THREE of:

- Any metal not normally live could be live.
- If the earth fault path is of high impedance the main fuse may not blow
- Fire hazard could occur through the main earth conductor carrying excessive current
- The earth bar/neutral bar/MEN link could be live at up to 230V.
- The neutral is being switched.
- 400V could be present at any socket outlet
- Damage could occur to any 400V appliance / motor
- Lighting circuits could have 400V present at the socket

(3 marks)

(b) (i) • Use a voltmeter, remote earth and trailing lead.

(1 mark)

- Take a voltage test at the main switch between each phase and the remote earth.

or

- Take a voltage test between the earth/neutral bar and the remote earth.

or

Take a voltage test between the metal enclosure of the meter box and the remote earth.

(1 mark)

(ii) If no transposition has taken place:

- The reading between the main switch and remote earth for each of the phases should be about 230 V

(1 mark)

- The reading between the neutral/earth bar and the remote earth should be about 0 volts.

(1 mark)

(iii) If a transposition has taken place:

- The reading at the main switch for the transposed phase should be about 0V
(1 mark)
- The reading at the main switch for the two phases not transposed should be about 230 V
(1 mark)
- The reading between the neutral/earth bar and the remote earth should be about 230 V.
(1 mark)

Note: The removal of the MEN link with the installation live is hazardous.
No marks for stating P-N=230V

QUESTION 7

$$\begin{aligned} \text{(a) (i) } I_{ph} &= \frac{P}{V_L \times \sqrt{3}} && \text{(1/2 mark)} \\ &= \frac{18000}{400 \times \sqrt{3}} && \text{(1/2 mark)} \\ &= 25.98A && \text{(1 mark)} \end{aligned}$$

$$\begin{aligned} I_{\text{fault}} &= \frac{V}{R} \\ &= \frac{231}{(6 + 9.75)} && \text{(1/2 mark)} \\ &= 14.67A && \text{(1 mark)} \end{aligned}$$

$$\begin{aligned} I_{\text{total}} &= I_{\text{fault}} + I_{\text{load}} = 14.67 + 25.98 && \text{(1/2 mark)} \\ &= 40.65A && \text{(1 mark)} \end{aligned}$$

- (ii) (1) The 40A fuses have a fusing factor (gG Utilisation Category) of 1.5
Fusing current = $1.5 \times 40 = 60A$.
(1/2 mark)

Because the fault current is 40.65 the fuses will not operate or the fuses will not operate within 0.4s
(1/2 mark)

- (2) V_d across protective earthing conductor equals touch voltage

$$\begin{aligned} V_{dE} &= I \times R \\ &= 14.67 \times 9.75. && \text{(1/2 mark)} \\ &= 142.35V && \text{(1/2 mark)} \end{aligned}$$

Touch voltage hazard of 142.35V exists between frame and earth
(1 mark)

$$\begin{aligned} \text{(b) } I &= 61A \\ R &= \frac{V}{I} && \text{(1/2 mark)} \\ &= \frac{230}{61} && \text{(1/2 mark)} \\ &= 3.77\Omega && \text{(1 mark)} \end{aligned}$$

Alternative solution:

$$\text{From (a)(i) } I_{\text{LOAD}} = 25.98\text{a}$$

$$I = 61 - 25.98 = 35.02\text{A}$$

$$R = \frac{V}{I}$$

(1/2 mark)

$$= \frac{230}{35.02}$$

(1/2 mark)

$$= 6.57\Omega$$

(1 mark)

QUESTION 8

(a) The procedure has to cover:

- Identifying and removing the correct fuses on the switchboard. (1 mark)
- Attaching a Danger tag to the circuit. (1 mark)
- Removing the isolator cover and testing for voltage at the supply side of the isolator using the prove-test-prove method. (2 marks)

(b) (i) • The control circuit operates at 230V. (½ mark)

• The control circuit is connected to the phase on which there is no fault. (½ mark)

- (ii) • Short between phase and earth in the wiring (½ mark)
- Short between phase and neutral in the wiring (½ mark)
- Short between phase and earth in the element (½ mark)
- Short between phase and neutral in the element (½ mark)

- (iii) • There is a breakdown in the insulation wiring between one phase and earth. (½ mark)
- One element has an insulation resistance of less than 10,000 ohms. (½ mark)

(iv) Any ONE Of:

- Circuit continuity test (for the last bullet point in (b)(ii) above)
- Insulation resistance test. (for the first three bullet points in (b)(ii) above) (1 mark)

(v) Insulation resistance test. (1 mark)

QUESTION 9

$$\begin{aligned} \text{(a)} \quad \frac{N_s}{N_p} &= \frac{V_s}{V_p} \\ V_s &= \frac{N_s \times V_p}{N_p} \\ &= 1 \times 11000 \div 47.8 \\ &= 230.13\text{V or } 230\text{V} \end{aligned}$$

(1/2 mark)
(1/2 mark)
(1 mark)

$$\begin{aligned} \text{(b)} \quad V_1 &= V_{ph} \times \sqrt{3} \\ &= 230.13 \times \sqrt{3} \\ &= 398.6\text{V or } 400\text{V} \end{aligned}$$

(1/2 mark)
(1/2 mark)
(1 mark)

$$\begin{aligned} \text{(c)} \quad \text{kVA} &= \frac{V_1 \times I_L \times \sqrt{3}}{1000} \\ &= \frac{11000 \times 13.12 \times \sqrt{3}}{1000} \\ &= 249.96 \text{ kVA or } 250 \text{ kVA} \end{aligned}$$

(1/2 mark)
(1/2 mark)
(1 mark)

$$\begin{aligned} \text{(d)} \quad I_L &= \frac{VA}{(V_1 \times \sqrt{3})} \\ &= \frac{250000}{(398.6 \times \sqrt{3})} \\ &\quad \text{or} \\ &\quad \frac{250000}{(400 \times \sqrt{3})} \\ &= 362.12 \text{ or } 360.85\text{A} \end{aligned}$$

(1/2 mark)
(1 mark)

$$\begin{aligned} \text{(e)} \quad \text{Regulation \%} &= \frac{V_{NL} - V_{FL} \times 100}{V_{NL}} \\ &= \frac{230 - 222 \times 100}{230 \quad 1} \\ &= 3.48\% \text{ or } 3.5\% \end{aligned}$$

(1/2 mark)
(1/2 mark)
(1 mark)