



Candidate Code No	
<b>For Board Use Only</b>	
Result	Result
Date	Date
Int	Int

# ELECTRICAL WORKERS REGISTRATION BOARD

## ELECTRICIAN'S THEORY EXAMINATION

18 June 2005

### QUESTION AND ANSWER BOOKLET

Time Allowed: Three hours

#### INSTRUCTIONS – READ CAREFULLY

You have 10 minutes to read this paper but do not start writing until you are told to do so by the supervisor.

Write your Candidate Code Number in the box provided above. Your name must NOT appear anywhere on this paper.

**The pass mark for this examination is 60 marks.**

**Answer**            **All questions in section 1**  
**Any FIVE questions in section 2.** (If you answer all questions in Section 2 strike out the question you do not want marked)

Use a pen for written answers. **Do not** use a pencil or a red pen.

Drawing instruments and pencils may be used when diagrams are required. Marks are allocated on the basis of correctness.

**Do not** use correcting fluid or correcting tape.

For calculation questions all workings, including formulae, must be shown to gain full marks.

Non-programmable calculators may be used.

**Warning** – You could get 0 marks for any question, or part of a question, if you show anything hazardous or dangerous in your answer.

**Candidates are not permitted to use any Act, Regulation, Standard, Code of Practice, Handbook or other reference text in this examination.**

**PLEASE HAND THIS PAPER TO THE SUPERVISOR BEFORE LEAVING THE ROOM.**

(turn over)

## SECTION 1

**Answer all questions in this section**

### **Question 1**

- (a) Give **TWO** examples which show how stroboscopic effects from fluorescent fittings can be minimised.

(1 mark)

(1) \_\_\_\_\_

\_\_\_\_\_

(2) \_\_\_\_\_

\_\_\_\_\_

- (b) What happens to the speed of a 3-phase induction motor when the load is increased?

(1 mark)

\_\_\_\_\_

\_\_\_\_\_

- (c) For a 400 V star-connected system, state the angle of phase displacement between the line voltages.

(1 mark)

\_\_\_\_\_

- (d) An HRC fuse with a Utilisation category (fusing factor) of 1.5 has a rating of 20 amps. Calculate the fusing current of this fuse.

(1 mark)

\_\_\_\_\_

\_\_\_\_\_

**(turn over)**

**Question 1 continued**

- (e) What is the minimum acceptable insulation resistance of an electrical installation that does not contain a heating appliance? (1 mark)

---

---

- (f) What is the purpose of a commutator on a d.c. generator? (1 mark)

---

---

- (g) What is the residual current rating of an RCD used for personal protection? (1 mark)

---

- (h) One end of a main earthing conductor must be connected to the main earthing terminal in the main switchboard. State **ONE** point where the other end of the main earthing conductor can be connected. (1 mark)

---

---

- (i) If three-phase motor has six terminals and windings rated at 230V how should it be connected to a 400V three-phase supply? (1 mark)

---

---

- (j) What do the figures AC 80 (or 80 kA) mean on an HRC fuse cartridge? (1 mark)

---

---

**(turn over)**

**Question 1 continued**

(k) What is the power factor in an a.c. circuit, when the true power equals the apparent power?

(1 mark)

---

---

(l) Name **TWO** components that are used to smooth the d.c. output of a rectifier.

(1 mark)

(1) \_\_\_\_\_

(2) \_\_\_\_\_

(m) What is the purpose of a centrifugal switch in a single-phase split-phase motor?

(1 mark)

---

---

(n) Name the **TWO** iron losses within a transformer.

(1 mark)

(1) \_\_\_\_\_

(2) \_\_\_\_\_

(o) What is the main difference between an MEN switchboard and a distribution switchboard?

(1 mark)

---

---

**(turn over)**

**Question 1 continued**

- (p) Briefly explain why an ohmmeter or a multimeter should not be used when carrying out an insulation resistance test on the internal wiring of a single phase electrical appliance.

(1 mark)

---

---

- (q) If a Residual Current Circuit Breaker (RCCB) is installed in a single phase circuit, why is it necessary to have overcurrent protection as well?

(1 mark)

---

---

- (r) A 400V three-phase motor has been repaired and is to be reconnected to a three core neutral-screened, fixed wired cable. List **ONE** advantage of using a neutral-screened cable when compared to a PVC cable.

(1 mark)

---

---

- (s) What is meant by the term pullout torque as it applies to an a.c. induction motor?

(1 mark)

---

---

- (t) What type of document is required to be issued by an electrician after the completion and testing of the wiring for a new low voltage installation?

(1 mark)

---

**(turn over)**

## Question 2

A three phase 400V induction motor has been removed from an industrial machine for cleaning and checking. It is supplied by a neutral-screened cable and controlled by a star/delta starter. The disconnection occurred at the starter so the cable is still connected to the motor. Checks must be carried out to ensure the motor is safe to reconnect.

- (a) Describe how the insulation resistance test should be carried out on the motor. Identify the type of instrument used, and state any minimum or maximum test values that are applicable.

(4 marks)

---

---

---

---

---

---

---

---

- (b) Describe how a circuit continuity test should be carried out on the motor. Identify the type of instrument used, and describe the expected test results.

(3 marks)

---

---

---

---

---

(turn over)

**Question 2 continued**

- (c) List the other checks or tests you would carry out on the motor before returning it to service.

(3 marks)

---

---

---

**(turn over)**

**Question 3**

- (a) State **TWO** reasons why a neutral conductor is required in the cable supplying a three-phase final subcircuit when it has heating loads that draw different values of current on each of the phases.

(4 marks)

(1) \_\_\_\_\_  
\_\_\_\_\_  
\_\_\_\_\_  
\_\_\_\_\_  
\_\_\_\_\_  
\_\_\_\_\_

(2) \_\_\_\_\_  
\_\_\_\_\_  
\_\_\_\_\_  
\_\_\_\_\_  
\_\_\_\_\_  
\_\_\_\_\_

**(turn over)**

**Question 3 continued**

- (b) The figure below shows a three-phase supply, consumers' neutral and earth bars, and protective fuses. It also shows a single-phase Class I appliance with a phase - to - frame fault on the load side of the appliance switch.

Sketch on the figure by using arrows, coloured pencil or high-lighter, the fault loop impedance path for this circuit.

(4 marks)

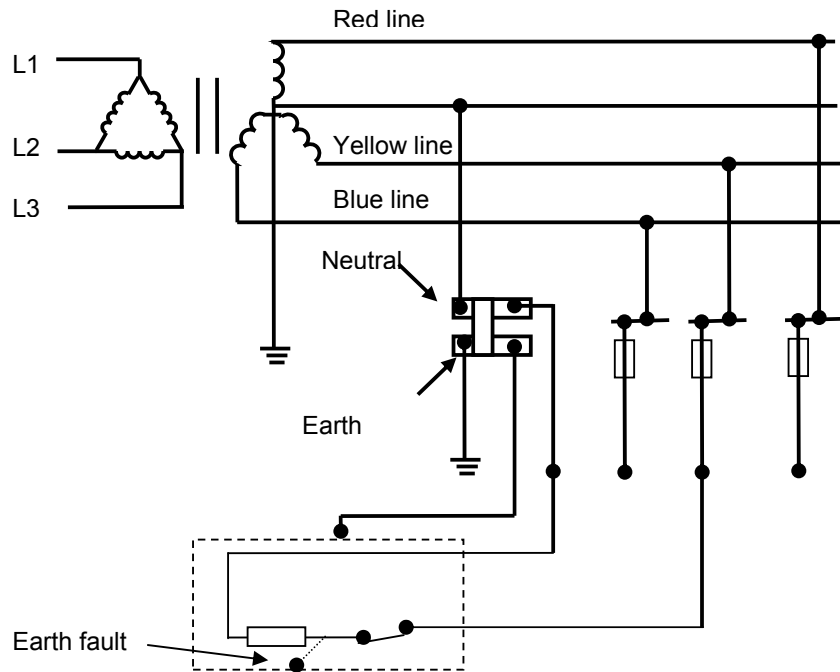

- (c) State **TWO** reasons why the neutral conductor is earthed in an MEN system.

(2 marks)

- (1) \_\_\_\_\_  
 \_\_\_\_\_
- (2) \_\_\_\_\_  
 \_\_\_\_\_

(turn over)

**Question 4**

(a) Rewireable fuses and HRC cartridge fuses may be found on switchboards. What would be the overall effect on a subcircuit when the protection device operates and the circuit is protected by:-

(i) An under-rated fuse? (1 mark)

---

---

(ii) An over-rated fuse? (1 mark)

---

---

(b) State **FOUR** technical advantages which HRC cartridge fuses have over rewireable fuses. (4 marks)

(1) 

---

---

---

(2) 

---

---

---

(3) 

---

---

---

(4) 

---

---

---

**(turn over)**

**Question 4 continued**

- (c) What is meant by the term inverse time-current characteristic in relation to fuses and circuit breakers?

(2 marks)

---

---

---

---

- (d) A miniature circuit breaker has both thermal and electromagnetic current-sensor functions. Briefly explain the operation of **ONE** function.

(2 marks)

---

---

---

---

**(turn over)**

## **SECTION 2**

(Answer any **FIVE** questions in this section. If you answer all questions, please strike out the question you do not want marked)

### **Question 5**

(a) Sketch and label a circuit diagram of an RCD used for personal protection that includes the following components:

- Sensing coil/toroid
- Block diagram of the tripping device
- Test circuit (push button and resistor)
- Phase, neutral and earth conductor.

(4 marks)

**(turn over)**

**Question 5 continued**

- (b) Describe the operation of the RCD circuit when there is a phase to earth fault (4 marks)

---

---

---

---

---

---

---

---

- (c) Explain the following terms: (2 marks)

PRCD \_\_\_\_\_

\_\_\_\_\_

RCBO \_\_\_\_\_

\_\_\_\_\_

**(turn over)**

### Question 6

Three resistive loads are connected in Star to a three-phase 400V, 4-wire supply. A clamp-on ammeter indicates currents of 10A in the red line, 20A in the yellow line and 15A in the blue line.

(a) Determine the current flowing in the neutral.

(4 marks)

(b) Calculate the power of each load.

(3 marks)

---

---

---

---

---

---

---

(turn over)

**Question 6 continued**

(c) Calculate the total power.

(1 mark)

---

---

(d) If the load current in the red line increases to 15A, state the effect on the neutral current and give the reason.

(2 marks)

---

---

---

**(turn over)**

**Question 7**

- (a) A 10 kW pump motor is to be disconnected at the motor terminal box and taken away for repair. When the motor is disconnected, the three-phase tails will be sitting on the ground. State **FOUR** precautions which must be taken to ensure your own safety and the safety of the public.

(4 marks)

(1) \_\_\_\_\_  
\_\_\_\_\_

(2) \_\_\_\_\_  
\_\_\_\_\_

(3) \_\_\_\_\_  
\_\_\_\_\_

(4) \_\_\_\_\_  
\_\_\_\_\_

- (b) What is the essential safety difference between switching an electrical appliance off and isolating an electrical appliance?

(3 marks)

\_\_\_\_\_  
\_\_\_\_\_  
\_\_\_\_\_  
\_\_\_\_\_  
\_\_\_\_\_  
\_\_\_\_\_

**(turn over)**

**Question 7 continued**

- (c) Describe **THREE** different ways of safely ensuring the continued isolation of a fixed-wired electrical appliance.

(3 marks)

---

---

---

---

---

---

**(turn over)**



**QUESTION 8 continued**

(b) Name **TWO** methods used to cool transformers.

(2 marks)



(1) \_\_\_\_\_

(2) \_\_\_\_\_

**(turn over)**

### Question 9

- (a) Complete the following table to show the output waveform and the ripple frequency of the stated single-phase rectifiers supplied at 230 V, 50 Hz:  
(3 marks)

	Single-phase half-wave rectifier	Centre-tapped full-wave rectifier	Single-phase full-wave bridge rectifier
Output waveform			
Ripple frequency			

- (b) Draw circuit diagram and label EACH component to show:
- (i) How a triac may control a 230 V ac incandescent lamp. Include a simple control circuit.  
(3 marks)

(turn over)

### **Question 9 continued**

- (ii) How a single diode may be used as a stand-by supply for a soldering iron.  
(2 marks)

- (iii) A 24 V, full-wave, centre-tapped rectifier circuit, with a resistive load, supplied from a 230/24 V transformer.  
(2 marks)

**(turn over)**





**For Candidate's Use**

In the box, write the number of **EXTRA** sheets you have used. Write **NIL** if you have not used any

<b>For Examiner's Use Only</b>		
<b>Questions Answered</b>	<b>Marks</b>	
1		
2		
3		
4		
5		
6		
7		
8		
9		
10		
<b>TOTAL</b>		